



E10

AGITATOR 6M³





**E10 UNDERGROUND
AGITATOR 6M3**





RELIABILITY AND PERFORMANCE IN TOUGH CONDITIONS.

Machine Safety

With safety as a priority, the E10 is engineered with onboard machine diagnostics for rapid fault identification, increasing the availability and productivity of the machine. The certified ROPS/FOPS air-conditioned operator cabin seats three persons comfortably. The ergonomic controls, excellent visibility, and LED lighting increase safety and reduce operator fatigue. The oscillating hitch, front suspension (optional) and air-ride seats provide unrivalled comfort for the operator. The electromagnetic braking retarder, adjustable from the operator's seat, provides superior and reliable braking capability.

Maintenance and Serviceability

A forward-tilting cabin, swing-out radiator grill, hinged engine bonnet cover, and hinged exhaust module, provide safe access for maintenance. Ground level access to service points reduce risk and time spent checking the machine status.

Machine Application

The E10 chassis is a multipurpose platform designed for various underground mining applications. Machine productivity is directly related to speed, capacity and reliability, all features considered by Elphinstone in the design of the Agitator. The Caterpillar powertrain provides haulage speeds on grade equivalent to production equipment resulting in maximum productivity across the mining fleet. The bowl has a maximum capacity of 6m³ and allows mixing of wet or dry product with variable speed control.

Contents

Structures, Work Tools and Attachments	4
Operator Environment	6
Safety Features	7
Engine	8
Powertrain	9
Product Features	10
Customer Support	12
Sustainability	12
Maintenance and Serviceability	13
Technical Specifications	14
Machine Dimensions	15
Standard and Optional Equipment	16
Your Notes	18



DELIVERING POWER AND CONTROL AT FULL CAPACITY.

Machine application

- » Bulk transport of concrete to back fill voids.
- » Transport of shotcrete to a shotcrete machine in a new development.
- » Excellent top speed at full capacity improves the cycle time and allows the machine to travel at the same speed as the production fleet resulting in increased production.

Wet or dry product loading

The 6m³ (7.8yd³) capacity agitator bowl can handle wet or dry product due to the machines ability to program mix and transit speeds which results in greater mixing versatility.

Dual loading access available

Loading of the agitator bowl can be achieved vertically via the chute or horizontally via conveyor (optional).

Water tank

Optional stainless steel water tank with flowmeter. On-board water storage to enable alterations to the batch or for wash down purposes.

Chemical agent tanks

Optional stainless steel chemical dosing tanks equipped with flowmeter. On-board chemical tanks to enable addition of agent in-situ at the work site.



Mixer

- » Electro/Hydraulically controlled for mixing and unloading.
- » Manual bowl controls at ground level.
- » Quick disconnect hydraulic fittings on bowl motor.
- » Slump meter.
- » Bolt on external bowl access covers.
- » Emergency stop switch at ground level.

Optional features include:

- » High mounted chute camera.
- » Chute extensions.
- » Ground level bowl guards.
- » High volume, low pressure water pump and hose reel.
- » Low volume high pressure water pump and hose reel for machine washdown.

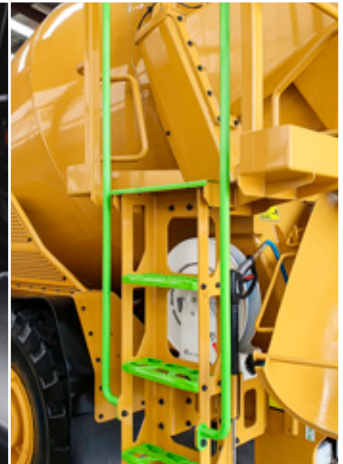

STRENGTH AND SUPERIOR BRAKING PERFORMANCE.

Heavy duty front frame

The robust, heavy-duty, and purpose design front frame utilises a high tensile steel construction with an average plate thickness of 20mm (0.80in). The frame design is common to both front and centre-mounted operator cabin options, both engine options and the option of front suspension or rigid axle.

The front suspension mounting points and fuel tank are incorporated into the common frame. The frame includes an access cover for cleaning and inspecting the fuel tank if required.

Rear frame

The rear frame uses high tensile steel box section construction with an average thickness of 12mm (0.47in). The agitator bowl can be positioned lower due to the increased width of the frame, reducing the overall height and centre of gravity.

Oscillating hitch

The oscillating hitch provides superior operator comfort, 4-wheel ground contact and reduced wear on the hitch and steering components. Includes a heavy duty 600mm (1ft 11in) deep frame section through oscillating hitch area with +/- 42.5° steering articulation and +/- 10° oscillation.

Electro-magnetic retarder

Fitted to the rear frame, the electronically controlled retarder provides superior braking performance on grade, featuring diagnostic capabilities with alarm and fault conditions reported back to the operator display. The integrated Retarder Control System (iRCS) combines both the control and power functions into a single unit. The innovative electronic design significantly reduces the retarder's energy consumption, preserving electric circuits. The retarder is controlled via an integrated multi-function joystick controller located on the operator's right-side armrest.

Agitator bowl transmission

The E10 agitator bowl features a transmission commonly used world wide in other cement mixing applications and has proven to be reliable and easily serviced.

Major advantages of the transmission include:

- » Tougher more robust design leading to increased bearing life.
- » Sealed for life servicing: reduced maintenance.
- » Vibration isolation via elastomer pad results in improved driving comfort.
- » Quick connect fittings on bowl motor for easy change over to auxiliary hydraulic power supply.
- » Variable speed output ranging from 0-19 rpm.



COMFORTABLE AND EASY TO OPERATE.

Two cabin configurations available

Fitted with a standard 3-seat open cabin, the E10 is also available with an optional air-conditioned, 3-seat enclosed cabin (pictured above). The enclosed cabin features ergonomics for operator comfort, user-friendly intuitive controls, and excellent 360-degree visibility.

The cabin includes the following features:

- » ROPS/FOPS certified design.
- » 300mm (12in) touch screen operator display.
- » Fingertip controls mounted to operators seat.
- » 3 full size seats. Air-ride suspension seat standard for driver, non-suspended seats for occupants. Optional Air-ride suspension seats for all persons.
- » Air conditioning and optional cab pressurisation.
- » Seat belts with occupant detection systems (operator seat).
- » Forward tilting cab for ease of maintenance.
- » Emergency stop inside cab.

Integrated multi-function joystick controller

The operator's right arm rest features an integrated multi-function joystick controller providing finite control in transit for agitator speed and machine braking performance.

Transmission controls

The keypad transmission control is conveniently located near the operator's right hand, with forward and reverse gears changed effortlessly with finger touch accuracy reducing driver fatigue.

Seating arrangements

The standard seating arrangement includes a centre driving position with two additional trainer/work-crew seats. The driver's seat is a 'T' seat with air suspension, and the crew seats are a standard 'T' seat or optional 'T' seat with air suspension. A storage compartment is optional if trainer/work-crew seating is not required. Retractable seat belts are standard with an occupancy indicator alarm system available as an option. The alarm is activated if the seat belt is not fastened as the machine brakes are released.

Steering column

The steering column can be adjusted to an ergonomic position for maximum operator comfort by tilting or extending the column.

Tilted cab mounting

The cabin is resiliently mounted to the machine chassis, reducing vibration for greater operator comfort and a quieter ride. The cabin tilts and locks into position with supports for safe and easy maintenance.

Touch screen operator display

The 300mm (12in) touch screen displays vital machine status information. Data collected includes engine coolant and transmission oil temperature, pitch and roll indicators, engine oil pressure, engine speed, an integrated camera system (up to 4x), and vehicle speed and fuel level.

Machine health monitoring system

The monitoring system and alarm strategy provides a 3-tier warning and shutdown functionality alerting the operator of any abnormalities and automatically limits the machine's functions.



SAFETY FEATURES



OPERATOR SAFETY IS OUR PRIORITY.

Machine isolation

All engine and machine isolation functions are conveniently located on one panel accessible from ground level. Switches have been designed to incorporate the requirement for the site tag in/out machine isolation process.

- » Battery isolation switch.
- » Starter isolation switch.
- » Jump start receptacle.
- » Fire system activation (optional).

Cabin protective structure

The operator cabin has an integrated Rollover Protective Structure (ROPS) certified to ISO 3471:2008 and Falling Object Protective Structure (FOPS) certified to ISO 3449:2005.

Handrails

Handrails are fitted standard in accordance with ISO 2867:2011. All handrails are painted green and designed for 3-point access to cab and machine.

Steering

Full hydraulic controlled steering via opposed cylinders at the oscillating hitch. Secondary emergency steering is also provided as standard.

Braking

Service brakes are hydraulic applied wet disc brakes. Emergency brakes are spring applied hydraulic release at the wheel ends. Braking systems meet ISO 3450:2011.

Additional safety features

- » Anti-skid step surfaces.
- » Inertia reel retractable seat belt.
- » Steering frame lock.
- » Electrical wiring segregation from all hydraulic hosing.
- » Fire resistant wiring.
- » Firewall / heatshields.
- » Machine interlocks (Battery and Starter) for additional protection.
- » Integrated fire suppression systems (optional).
- » Hydraulic hosing covered with burst protection sleeves.
- » Door ajar warning (Operator Presence) systems.
- » Door lighting for better step visibility.
- » Window egress cord for ease of cab window removal.
- » Rear view camera.
- » Park brake interlocking.
- » Bowl lifting points and bowl rotation.

Ground level servicing access

Allows convenient servicing to tanks, filters, lubrication points and compartment drains.

Speed control

Speed control allows the operator to set the maximum speed on grade and the machine uses the electromagnetic retarder and the powertrain inertia to maintain the speed.

When on flat ground the operator can accelerate over the maximum set speed however when the accelerator pedal is released the machine will reduce speed back to the maximum speed setting.

DELIVERS POWER, PERFORMANCE AND DURABILITY.

C7.1 engine

The Cat C7.1 uses Caterpillar's breakthrough ACERT™ Technology to meet exhaust emission reduction standards. It features efficient fuel delivery, air management and electronic control for high productivity and exceptional service life.

The C7.1 ACERT Tier 3 engine arrangement rated at 168 kW (228 hp) is standard for regions that may not have Ultra Low Sulphur Fuel or more stringent emission regulations. An optional diesel particulate filter can be fitted.

The C7.1 ACERT Tier 4 Final engine arrangement is available as an option, adhering to EU Stage IV exhaust emission standards. This arrangement is rated at 151kW (202 hp).

ADEM A4 engine control module

The ADEM A4 module controls the fuel injector solenoids to monitor fuel injection. It also provides automatic altitude compensation, and will not allow the engine to start until it has oil pressure, acting as cold start protection and a form of pre-lube.

Maintenance

The C7.1 engine reduces costs and downtime with 500-hour oil change intervals. The E10 is equipped with Caterpillar high efficiency oil filters, a design which doubles efficiency without increasing the change interval.

Engine protection system

An engine protection system is fitted that will shut down the engine if low engine oil pressure, low coolant level, or coolant over temperature conditions are experienced.

Commonality

The Caterpillar C7.1 engine is found in several Caterpillar products and applications such as Medium Wheel Loaders, Excavators, Motor Graders, Marine and Industrial services. This means the E10 shares component commonality across many applications, providing the highest level of reliability and durability, as well as superior parts availability worldwide through the Caterpillar Dealer Network.





PERFORMANCE AND RELIABILITY IN TOUGH CONDITIONS.

Caterpillar five-speed transmission

The field proven Cat power shift countershaft transmission easily matches engine power to the load size and ground conditions. Gear changes are simplified with ergonomically positioned electronic fingertip controls, reducing operator fatigue.

Electro-magnetic retarder

Fitted to the rear frame, the electronically controlled retarder provides superior braking performance on grade, featuring diagnostic capabilities with alarm and fault conditions reported back to the operator display. The integrated Retarder Control System (iRCS) combines both the control and power functions into a single unit. The innovative electronic design significantly reduces the retarder's energy consumption, preserving electric circuits. The retarder is controlled via an integrated multi-function joystick controller located on the operator's right-side armrest.

Reduced shifting

The multiplication capability of the torque converter reduces the need for the operator to continually shift the transmission. This reduces operator effort and improves machine productivity.

All wheel drive (AWD)

All-wheel drive provides excellent power distribution, increases traction of the machine reducing tire slippage, improving performance, handling and manoeuvrability in tough and challenging terrain.

Front and rear axles

The front axle is rigid mounted design with front suspension available as an option. The rear axle is rigidly mounted to the rear frame.

Tyres

Tyres are an integral part in a machines ability to carry it's load at higher speeds. Fitted with the larger 14:00 R20 Radial tires ensures the E10 stays within the tires TKPH limits. This allows the E10 to carry larger loads at faster speeds than conventional utility equipment.

Service brakes

Hydraulically applied spring release brake system. Brake components are oil immersed inside the axles, protecting them from contamination. Modulated braking provides smooth deceleration for precision stopping and operator control.

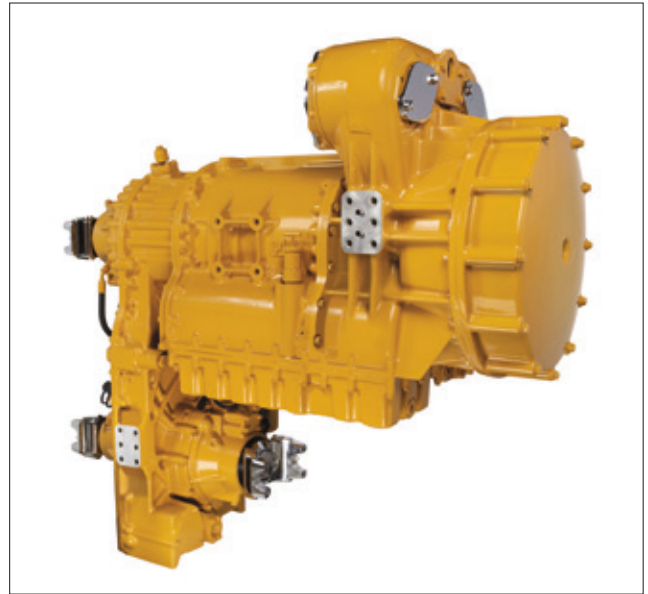

Parking brake

The parking brake is a spring applied oil released "fail to safe" enclosed wet disc on all 4-wheel ends.

Brake design

With large discs and plates for reliable, adjustment free operation and performance. Oil cooled disc brakes are completely enclosed to prevent contamination and reduce maintenance.

Emergency braking

When the E10 safety system detects loss of critical drive pressure or brake pressure the operator will receive a warning and then the parking brake system will be safely apply.

Load sensing

A load sensing variable displacement pump and pressure compensating system continually monitor hydraulic power requirements, then provides power based on demand. This improves fuel economy and reduces emissions.

Other features include suction circuits, pump case-drain and steering return, filtered fan/brake pressure circuit, and closed loop hydraulic system.



FEATURE OVERVIEW

DELIVERING SHOTCRETE OR CONCRETE ON TIME WITH IMPROVED RIDE CAPABILITY.

● Standard ● Optional ● Safety

HINGED ENGINE BONNET

Allows easy access to engine and exhaust system

LED LIGHTING

All operation lighting

3-SEAT OPEN CABIN ROPS/FOPS CERTIFIED

Cabin tilt for maintenance and serviceability

REAR WINDOW GUARD

3-SEAT ENCLOSED CABIN CLIMATE CONTROLLED ROPS/FOPS CERTIFIED

Superior operator comfort and cabin tilt for maintenance and serviceability

SWING OUT RADIATOR GRILL

Provides easy access to facilitate cleaning and maintenance on cooling system

HYDRAULIC OIL TANK

Located on RHS of engine

RETARDER DIAL CONTROLLER

Located on the operator's arm rest

BOLT-ON RADIATOR COVER

ENCLOSED BATTERY COMPARTMENT

MACHINE LIFTING POINTS

Painted red

FIRE SUPPRESSION ACTUATION

ARTICULATION LOCK

OSCILLATING HITCH

Provides superior operator comfort while maintaining constant ground contact

EMERGENCY STOP

MACHINE ISOLATION

Located at ground level adjacent to operators cabin

MACHINE TIE DOWN POINTS

GROUND LEVEL ACCESS TO ALL FILTERS AND SERVICE POINTS

All filters and service points can be serviced from ground level on the access platforms on either side at the front of the machine

WHEEL CHOCKS x2

Stored below grill

CENTRE MACHINE RETRIEVAL POINT

Painted red

ELECTRO-MAGNETIC BRAKING RETARDER

Adjustable from the operator's seat, provides superior and reliable braking capability



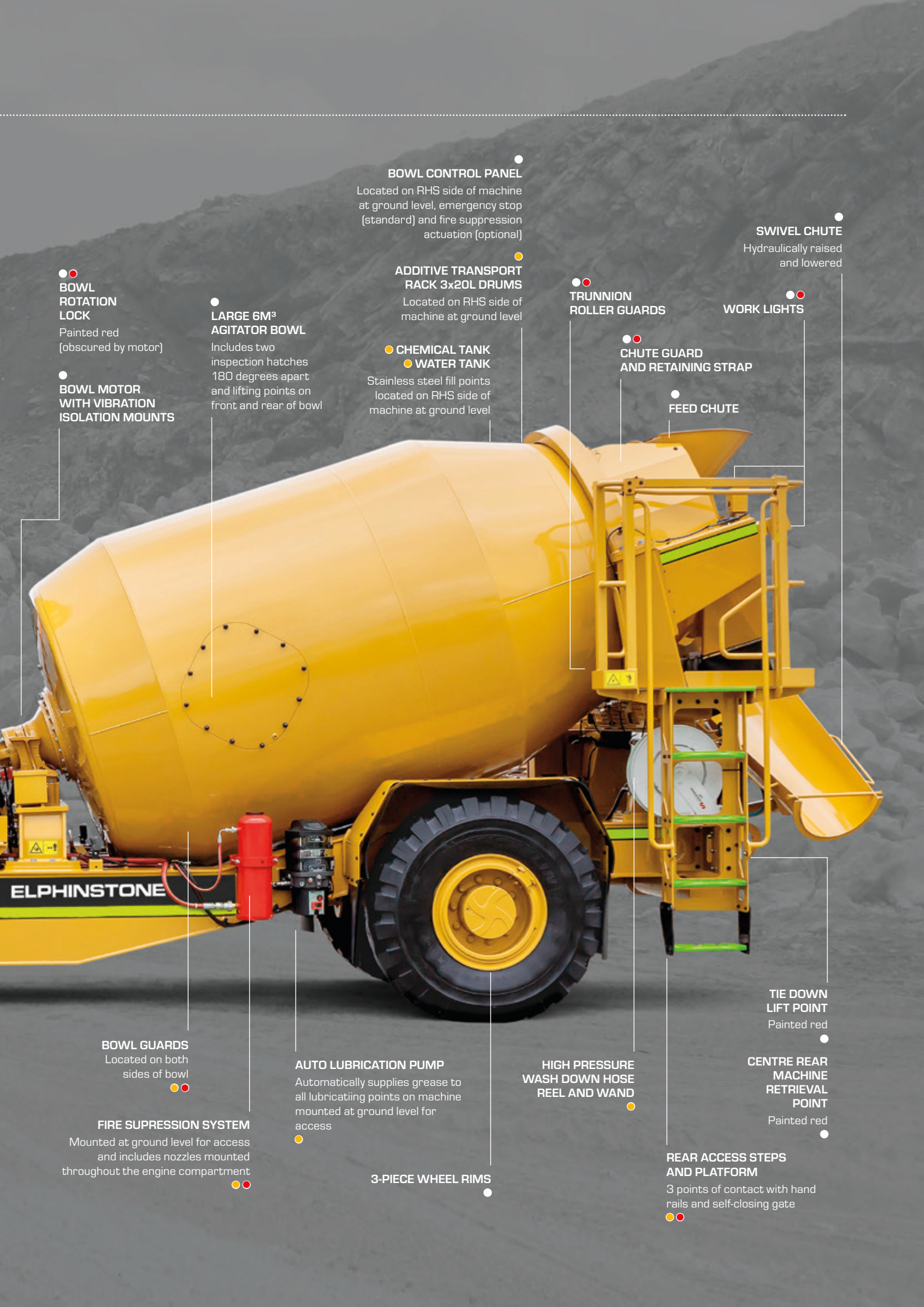

●●
BOWL ROTATION LOCK
Painted red
(obscured by motor)

●
BOWL MOTOR WITH VIBRATION ISOLATION MOUNTS

●
LARGE 6M³ AGITATOR BOWL
Includes two inspection hatches 180 degrees apart and lifting points on front and rear of bowl

●
BOWL CONTROL PANEL
Located on RHS side of machine at ground level, emergency stop (standard) and fire suppression actuation (optional)

●
ADDITIVE TRANSPORT RACK 3x20L DRUMS
Located on RHS side of machine at ground level

●●
CHEMICAL TANK
● WATER TANK
Stainless steel fill points located on RHS side of machine at ground level

●●
TRUNNION ROLLER GUARDS

●●
WORK LIGHTS

●●
CHUTE GUARD AND RETAINING STRAP

●
FEED CHUTE

ELPHINSTONE

●●
BOWL GUARDS
Located on both sides of bowl

●●
FIRE SUPPRESSION SYSTEM
Mounted at ground level for access and includes nozzles mounted throughout the engine compartment

●
AUTO LUBRICATION PUMP
Automatically supplies grease to all lubricating points on machine mounted at ground level for access

●
3-PIECE WHEEL RIMS

●
HIGH PRESSURE WASH DOWN HOSE REEL AND WAND

●●
REAR ACCESS STEPS AND PLATFORM

3 points of contact with hand rails and self-closing gate

●
TIE DOWN LIFT POINT
Painted red

●
CENTRE REAR MACHINE RETRIEVAL POINT
Painted red

●
SWIVEL CHUTE
Hydraulically raised and lowered



CUSTOMER SUPPORT

WHEN UPTIME REALLY COUNTS.

Renowned Cat dealer support

From helping you choose the right machine to financing and ongoing support, your Cat dealer provides the best in sales and service.

- » Manage your costs with preventive maintenance programs like SOS™ fluids analysis, coolant sampling.
- » Stay productive with best-in-class parts availability.
- » our Cat dealer can also help you boost efficiency with operator training.
- » When it's time for component replacement, your Cat dealer can help you save even more. Genuine Cat remanufactured parts carry the same warranty and reliability as new products at savings of 40 to 70 percent for powertrain and hydraulic components.
- » Technical training and maintenance planning are also part of the Dealer offerings.
- » Would you like the Dealer to do more? Programs such as Customer Service Agreements, to a full Maintenance and Repair contract are available.

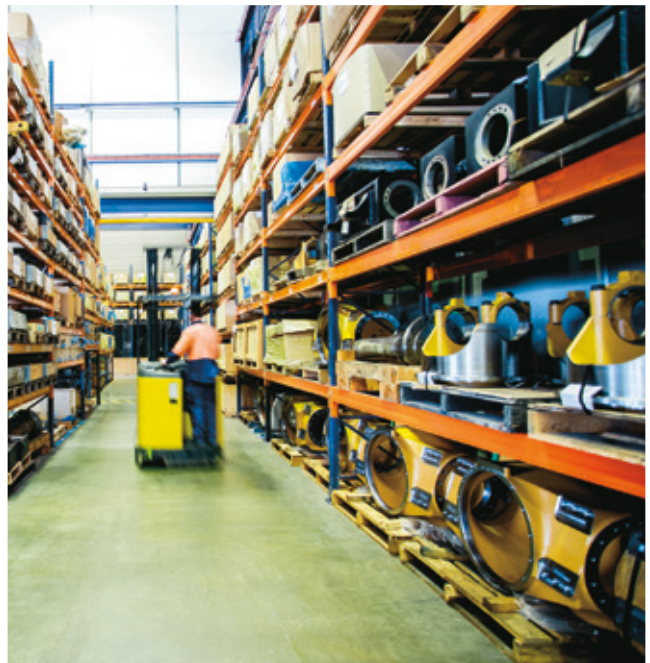

FUTURE SUSTAINABILITY

THINKING INTO THE FUTURE.

Sustainable waste and cost management

- » Integrated machine systems and technologies improve productivity for greater accuracy, lower fuel use and reduce machine wear.
- » Replaceable wear parts save maintenance time and cost and extend major component life.
- » Ecology drains help make draining fluids more convenient and help prevent spills.
- » Major components are built to be rebuilt, eliminating waste and saving customers money by giving the machine and/or major components a second – and even third life rebuilds.
- » A variety of safety features help safeguard operators and others on the job.





SERVICEABILITY MEANS MORE TIME FOR PRODUCTION.

Engine access

Forward tilting cabin, swing out radiator grill, hinged bonnet and exhaust module make regular maintenance quick and easy. Easy access to daily service points increases the likelihood that maintenance will be done resulting in increased machine service life. In addition, less maintenance time means more working time and greater productivity.

Frame access

Steps and grab handles positioned for 3-point contact are standard for easy access to the service and operation areas.

Bolt-on guards

Bolt-on guards offer protection to critical components and are easily removable for servicing. Removable floor plates and side plate allow access to components under the cab.

Air filters

Air filters are easy to change, reducing air filter maintenance times.

Extended oil service intervals

A 500-hour oil change interval reduces downtime for service and lowers maintenance costs.

SOS™ fluid sampling valves

Provides a fast, convenient way to gather uncontaminated fluid samples, which improves analysis reliability.

Pressure taps

Conveniently located for easy access to hydraulic system pressure measurements.

Electrical system

The 24V electrical system delivers a reliable electrical capacity for engine starting and additional lighting. Wiring circuits are colour coded and numbered for easy diagnosis and repair. All circuits are protected by circuit breakers. Wiring is double insulated with sealed electrical connectors to prevent moisture and dirt access. Harnesses are covered with fire resistant material for additional protection.

On-board diagnostic systems

The monitoring system continuously checks all critical machine functions and components and helps locate faults quickly for faster repair.

Hitch hoses

- » The pilot hoses, pressure line and load sense lines have all been routed above the hitch and bulk-headed for easy hose replacement and fast service.
- » Spin-on oil filters.
- » Spin-on fuel and engine oil filters shorten downtime.
- » Electronic transfer pump eliminates the need to manually prime the fuel system.

Centralised service centre

A centralised service centre that includes fast fill and evacuation points (optional).



TECHNICAL SPECIFICATIONS

Engine

Engine Tier	Tier 3 - Standard		Tier 4 Final (Low Power)		Tier 4 Final (High Power)	
Engine Model	Cat C7.1 ACERT (TA)		Cat C7.1 ACERT (TA)		Cat C7.1 ACERT (TA)	
Gross Power SAE J1995	168 kW	225 hp	129 kW	173 hp	151 kW	202 hp
Displacement	7.0131 L	428 in ³	7.0131 L	428 in ³	7.0131 L	428 in ³
Bore	105 mm	4.1 in	105 mm	4.1 in	105 mm	4.1 in
Stroke	135 mm	5.3 in	135 mm	5.3 in	135 mm	5.3 in
Number of Cylinders	6		6		6	
Max Torque @ Rated Speed	1028 Nm @ 1400 rpm		842 Nm @ 1400 rpm		870 Nm @ 1400 rpm	
Derating Altitude	3000 m	9843 ft	3000 m	9843 ft	3000 m	9843 ft
Emission Certification	EPA Tier 3		EPA Tier 4 Final		EPA Tier 4 Final	
Alternator	150 amp		150 amp		150 amp	
Electrical System	24 V		24 V		24 V	
Battery - Quantity	2		2		2	
Battery - Volts	12 V		12 V		12 V	
Battery - Capacity	1000CCA		1000CCA		1000CCA	
Starting System	Direct Electric		Direct Electric		Direct Electric	

- Power ratings apply at 2200 rpm when tested under the specified standard conditions.
- Based on standard air conditions of 25° C (77° F) and 99 kPa (29.32 in Hg) dry barometer. Used 35° API gravity fuel having an LHV of 42,780 kJ/kg (18,390 BTU/lb) when used at 30° C (860 F) [ref. A fuel density of 838.9 g/L (7.001 lb/gal)].

Powertrain

Travel Speed - Fwd. 1st	5.7 km/h	3.5 mph
Travel Speed - Fwd. 2nd	9.4 km/h	5.8 mph
Travel Speed - Fwd. 3rd	15.0 km/h	9.3 mph
Travel Speed - Fwd. 4th	20.0 km/h	12.4 mph
Travel Speed - Fwd. 5th	32.2 km/h	20.0 mph
Travel Speed - Rev. 1st	5.7 km/h	3.5 mph
Travel Speed - Rev. 2nd	9.4 km/h	5.8 mph
Travel Speed - Rev. 3rd	20.0 km/h	12.4 mph
Torque Converter Type	Lock-up clutch	
Transmission	5 fwd / 3 rev countershaft powershift	
Steering, Frame Articulation	42.5 degrees	
Brakes - Service Type	Hydraulic applied inboard WET disc enclosed	
Brakes - Parking Type	Internal Spring Applied Hydraulically Released wheel ends (SAHR)	
Tyres	14.00 R20	

Service Refill

Fuel Tank	340 L	89.8 gal
Cooling System	50 L	13.2 gal
Differential, Final Drive - F	18.5 L	4.9 gal
Differential, Final Drive - R	20.5 L	5.4 gal
Engine Oil	13.5 L	3.6 gal
Transmission, Torque Converter	31 L	8.2 gal
Hydraulic Tank	150 L	39.6 gal
Bowl Geared Head	8 L	2.1 gal
Diesel Exhaust Fluid (DEF) (Tier 4 Final Only)	16 L	4.2 gal

Weights

Gross Vehicle Weight (GVM)	29,400 kg	64,815.9 lb
Tare Weight	16,925 kg	37,313.2 lb

*Tare weight includes one operator and a full tank of fuel.

Speed on Grade

Cat C7.1 ACERT, 168kW Tier 3					
Grade	Vehicle Speed (km/h)				
	1st Fwd	2nd Fwd	3rd Fwd	4th Fwd	5th Fwd
1:7 (14%) Empty (16,925 kg)	5.7	9.4	15.0	20.0	-
1:7 (14%) GVM (29,400 kg)	5.7	9.4	10.9	-	-
Cat C7.1 ACERT, 151kW Tier 4 Final (High Power)					
Grade	Vehicle Speed (km/h)				
	1st Fwd	2nd Fwd	3rd Fwd	4th Fwd	5th Fwd
1:7 (14%) Empty (16,925 kg)	5.7	9.4	15	17.3	-
1:7 (14%) GVM (29,400 kg)	5.7	9.4	-	-	-
Cat C7.1 ACERT, 129kW Tier 4 Final (Low Power)					
Grade	Vehicle Speed (km/h)				
	1st Fwd	2nd Fwd	3rd Fwd	4th Fwd	5th Fwd
1:7 (14%) Empty (16,925 kg)	5.7	9.4	15.0	15.5	-
1:7 (14%) GVM (29,400 kg)	5.7	8.9	-	-	-

*Note: 2% rolling resistance

Agitator

Drum Volume						
Mixing / Carrying Capacity					6m ³	
100% Drum Volume					9.4m ³	
Bowl Capacities						
Material SG (kg/m ³)	2000	2100	2200	2300	2400	2500
Max. Fill Capacity (m ³)	6	5.8	5.6	5.3	5.1	4.9

Standards

ROPS/FOPS	ISO 3471:2008 / ISO 3449:2005
Steering	ISO 5010:2007
Braking	ISO 3450-2011/CSA-M424.3-M90



MACHINE DIMENSIONS

Turning Radius

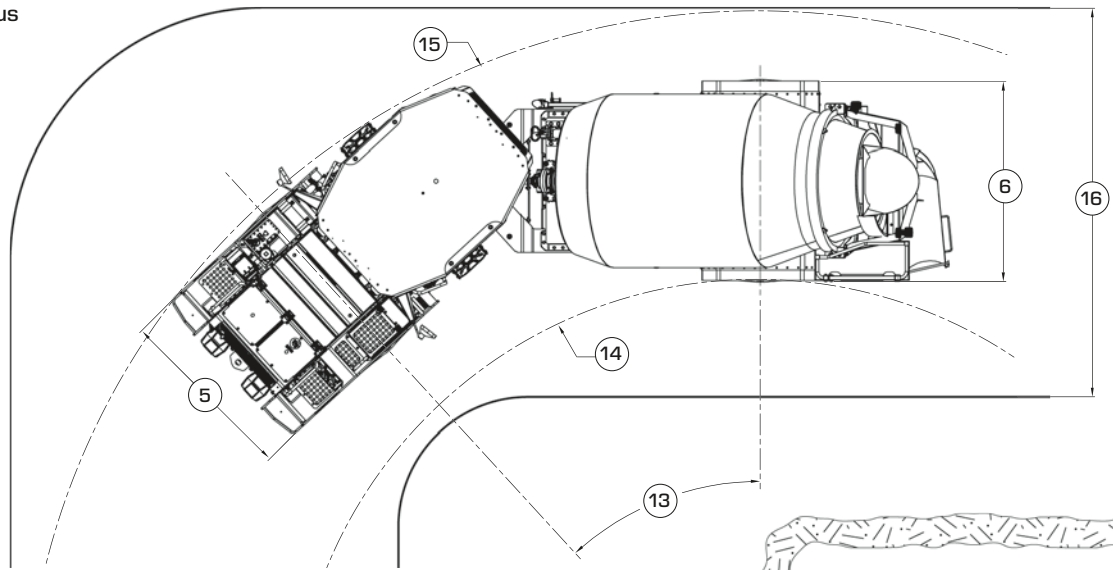

Side View and Drive Size

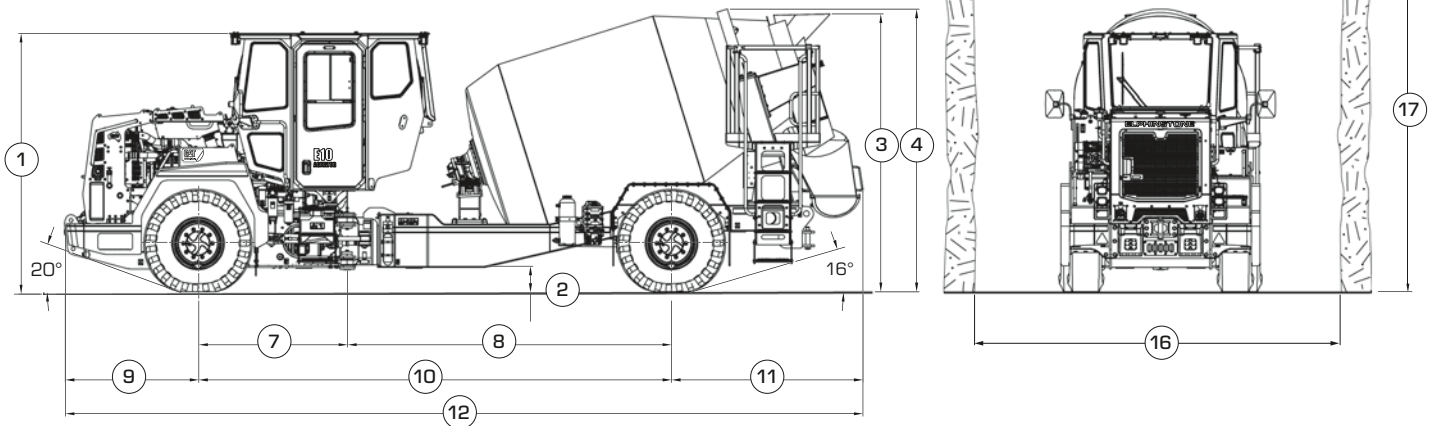

Dimensions

1	Height - Top of Cabin	3000 mm	9 ft 10.1 in
2	Height - Ground Clearance	305 mm	1 ft 0 in
3	Height - Top of Feed Chute	3225 mm	10 ft 7 in
4	Height - Top of Agitator	3280 mm	10 ft 9.1 in
5	Width - Machine Front Frame	2100 mm	6 ft 10.6 in
6	Width - Machine Rear Frame	2315 mm	7 ft 7.1 in
7	Length - Front Axle to Hitch	1725 mm	5 ft 7.9 in
8	Length - Hitch to Rear Axle	3750 mm	12 ft 3.6 in
9	Length - Front axle to bumper	1545 mm	5 ft 1 in
10	Length - Wheel Base	5475 mm	17 ft 11.6 in
11	Length - Rear Axle to Chute	2215 mm	7 ft 3.2 in
12	Length - Overall	9235 mm	30 ft 3.6 in
13	Articulation	42.5 deg	

Drive Size

14	Radius - Inside Clearance - By design	5496 mm	18 ft 0.4 in
15	Radius - Outside Clearance - By design	8606 mm	28 ft 2.8 in
16	Minimum Width Portal (90° corner)	4500 mm	14 ft 9.1 in
17	Typical Minimum Height Portal	4500 mm	14 ft 9.1 in



STANDARD AND OPTIONAL EQUIPMENT

● Standard ● Optional ● Safety

Powertrain

Air Cleaner, 2-Stage With Integral Pre-Cleaner	●
All Wheel Drive with Lock-up Torque Converter	●
Axle Breathers, Remote Mounted	●
Brakes - Parking, Four Wheel Spring Applied, Enclosed Disc	●
Brakes - Service, Four-Wheel Pressure Applied Enclosed Disc	●
Brake - Driveline, Electromagnetic Retarder	●
Driveline Slip-joint, Lubed for Life	●
Engine, Cat C7.1, ACERT Technology, ATAAC - Tier 3	●
Engine, Cat C7.1, ACERT Technology, ATAAC - Tier 4 Final	●
Fan, Sucker	●
Filters, Engine Air, Primary/Secondary	●
Filters, Fuel, Primary/Secondary	●
Final Drives, Outboard Planetary	●
Fuel Transfer Pump (Electric)	●
Fuel Lines - Double Wire Braided	●
Fuel Shutoff Valves Supply & Return	●
Lock - Wheel Nut (Torque Retention)	●
Muffler/Catalytic Converter (Tier 3 Only)	●
Oscillating Hitch	●
Radiator	●
Steering, Rotary Metering Pump	●
Suspension, Front Axle	●
Transmission, Countershaft Powershift (5F/3R)	●
Universal Joints, Lubed for Life	●
Fast-Fill Systems	
Coolant, Engine Oil, Hydraulic Oil, Transmission Oil	●
Fuel, Non-pressurised	●

Antifreeze

Coolant, Extended Life for -35°C (-30°F)	●
Coolant, Arctic Extended Life for -50°C (-58°F)	●

Operator Environment

300 mm (12 in) Touch Screen Operator Display	●
Brake Retarder Control	●
Cabin, Open, FOPS/ROPS	●
Cabin, Enclosed, FOPS/ROPS, Climate Control Modular 24 V HVAC System, Sliding Door Window	●
Cabin, Pressuriser	●
Cabin, Rear Window Wiper and Washer	●
Cabin, Tilt Supports	●
Cabin, Tilt Supports, Reduced Height	●
Cabin, Window Guard, Rear	●
Camera/Monitor, Reversing	●
Diagnostic Connector	●
Engine Idle Timer	●
Fire Extinguisher 2.5 kg, Hand Held Dry Chemical Powder 3A:40B:E LH Side	●
Fire Extinguisher 2.5 kg, Hand Held Dry Chemical Powder 3A:40B:E RH Side	●
Interior Lamps (LED)	●
Mirrors, Rear View	●
Seat Belt, 3x Retractable, Occupancy Indicator	●
Seat, T-Seat, Air Suspension, Operator	●
2x Seat, T-Seat, Air Suspension, Companion	●
Seat Covers, Operator and Companion	●
Steering Wheel, Tilt and Telescoping	●

Operator Environment

Instrumentation, Gauges	
Brake, Accumulator Pressure	●
Brake, Oil Pressure	●
Diesel Exhaust Fluid (DEF) (Tier 4 Final Only)	●
Engine, Coolant Temperature	●
Engine, Oil Pressure	●
Fuel, Level	●
Hydraulic, Oil Temperature	●
Pressuriser Air Filter, High Efficiency Particulate Air	●
Pressuriser Air Filter, Activated Charcoal	●
Speedometer	●
Steering, System Pressure	●
Tachometer	●
Torque Converter, Oil Temperature	●
Instrumentation, Warning Indicators	
Brake, Accumulator Oil Pressure	●
Brake, Fault	●
Brake, Park Indicator	●
Cabin, Door Open	●
Electrical System	●
Emergency Stop	●
Engine, Coolant Temperature	●
Engine, Fault	●
Engine, Oil Pressure	●
Hydraulic, Oil Level	●
Hydraulic, Oil Temperature	●
Steering, Primary	●
Steering, Secondary	●
Torque Converter, Oil Temperature	●
Transmission, Fault	●
Transmission, Oil Filter Bypass	●
Instrumentation, Digital Data	
Gear and Direction	●
Driveline Retarder, Braking Percentage	●
Service Hour, Meter	●
Electrical	
Accessory Power Port (12 V) & (24 V)	●
Alarm, Back-up	●
Alternator, 150 amp	●
Auxiliary Start Receptacle	●
Batteries, Maintenance Free (2x1000 CCA)	●
Battery Isolation, Lockable Disconnect Switch (4 Pole)	●
Emergency Stop - Cabin	●
Emergency Stop - Ground Level, LH Side Front	●
Emergency Stop, Additional, RH Side Front	●
Horn, Warning	●
Lights, Beacon (LED), Cab Mounted (Amber/Red/Blue)	●
Lights, Headlights (LED)	●
Lights, Reversing	●
Lights, Stop/Tail/Turn (LED)	●
Lights, Work, Front/Rear - Cab Mounted (LED)	●
Lights, Work, Front/Rear - Cab Mounted (LED) Additional	●
Radio, Ready, Communications	●
Radio, AM/FM/USB/Bluetooth	●
Sealed Electrical Connectors	●
Starter, Electric, Heavy Duty	●
Starter Isolator, Lockable Disconnect Switch (4 Pole)	●
Starting and Charging System, 24 V	●



STANDARD AND OPTIONAL EQUIPMENT

● Standard ● Optional ● Safety

Hydraulics

Case Drain Return Screen	●
Closed Center-load Sensing System	●
Hydraulic Oil Cooler	●
Hydraulic Oil Filling System, Filtered	●
Line Filter, Full Flow Return	●
Suction Screen	●

Agitator

Bowl, Auxiliary Motor Quick Connection Fittings	●
Bowl, Access Platform/Ladder - Rear LH Side	●
Bowl, Controls, Cabin	●
Bowl, Controls, Fixed, Rear	●
Bowl, Guards	●●
Bowl, Lifting Hardware	●
Bowl, Lock	●●
Bowl, Maintenance Access Covers	●
Camera, Rear, Discharge Chute, Mounted	●
Chute Extensions, Base/Extension/Placement	●
Tank, Chemical Additive	●
Emergency Stop, Ground Level, RH Side Rear	●●
Lights, Work, Rear (LED) x6	●
Water Pump, High Pressure, Hose, Reel, and Lance	●
Water Pump, Low Pressure, Hose, Reel	●
Tank, Chemical Additive	●
Tank, Water	●
Slump Meter Gauge, Rear	●
Operator Display	
Bowl, Speed (RPM)	●
Current Mode of Operation - Plant Mix, Transit Mix, Discharge	●
Slump Meter, Cab	●

Other

Brakes, Park, Onboard, Release for Machine Retrieval	●●
Engine, Enclosures, Hinged (Tier 3 Only)	●
Film, GP Reflective, Flourescent Yellow	●●
Film, GP Reflective, Flourescent Orange	●●
Fire Extinguisher, 4.5 kg, Hand Held Dry Chemical Powder 4A:60B:E LH and RH Side	●●
Fire Extinguisher, 9 kg, Hand Held Dry Chemical Powder 6A:80B:E LH and RH Side	●●
Fire Suppression System, Ansul A101 Dry Chemical Powder, Engine Shutdown	●●
Fire Suppression System, Sandvik Aqueous-Film Forming Foam, Engine Shutdown	●●
Grease Lubrication System, Centralised, Manual	●
Grease Lubrication System, Automatic	●
Lift, Tie Down and Retrieval Points (Front and Rear)	●
Mudguards	●
Radiator, Cap, Manual Pressure Release	●
Scheduled Oil Sampling (SOS) ports	●
Steering, Frame Lock Link	●
Steering, Secondary	●
Tyres, Tubeless Rims (14.00 R20)	●
Tyre and Rim, Spare (14.00 R20)	●
Unit Number Placard	●
Wheel Chocks	●●

OVER 50 YEARS IN THE MINING INDUSTRY.

Elphinstone Pty Ltd is an established Caterpillar OEM Solutions customer with over 50 years' experience in the mining industry.

Elphinstone specialises in the design, manufacture and support of quality equipment for the global underground and surface mining industries.

The Elphinstone range of products combines practical design, the latest technology and quality manufacturing to ensure reliable performance.

The current product range includes specialised underground support vehicles, mine extraction devices, extended distance off-highway haulage trucks and water tanks designed to fit Caterpillar 740C, 745C and 745 articulated trucks.

All Elphinstone products, technical assistance, support, and access to spare parts are available through the global Cat® dealer network with additional support from the Elphinstone regional sales and support team.

E10 AGITATOR 6M³

For more complete information on Elphinstone products, dealer services, and industry solutions, visit www.elphinstone.com or contact your local Cat® dealer.

Material and specifications are subject to change without notice. Featured machines in photos may include additional equipment.

Elphinstone and their respective logos, as well as corporate and product identity used herein, are trademarks of Elphinstone and may not be used without permission.

© 2026 Elphinstone. All rights reserved.
Made in Australia for export.

ELPHINSTONE



HM28407-05 (05-2026)