

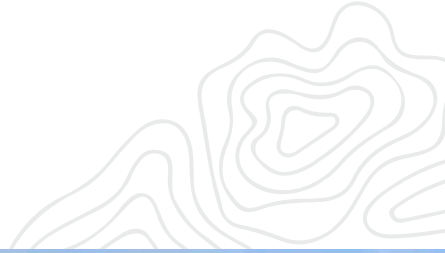

EG20

MOTOR GRADER



Elphinstone Underground Support Solutions
elphinstone.com

Main image is referential and may include optional components.

ELPHINSTONE

UNDERGROUND RELIABILITY



**EG20 UNDERGROUND
MOTOR GRADER**





FOR IMPROVED PRODUCTIVITY AND RELIABILITY UNDERGROUND.

Improved machine safety and ergonomics

With safety as a priority, the new and improved EG20 is engineered for safety underground. The Roll Over Protection System (ROPS) and Falling Object Protection System (FOPS) cab provides a safe environment with low vibration levels reducing operator fatigue so they remain efficient, productive and safe all day. Laminated glass front windows and lockable doors are standard. Brake lights, cameras, conveniently located grab rails, back up lights, and alarms help to ensure a safe work environment.

Cab ergonomics have been improved significantly in the EG20. The seat, implement controls, and steering wheel angle are all adjustable for a greater range of movement allowing the operator to personalise their operating position. Dashboard and camera screens are positioned directly in front of the operator and the front lower windows enlarged for improved visibility.

Maintenance and Serviceability

Grouped service points make daily maintenance easier and faster while enhanced diagnostics and monitoring via Cat Product Link help reduce downtime. Ground level access to service points reduce risk and time spent checking the machine status.

Machine Application

Simple and robust, the EG20 can significantly increase the productivity of the production fleet and reduce operational cost by maintaining haul roads. The EG20 can be optioned with many additional features to suit specific mine site applications.

Contents

Structures Drawbar-Circle-Moldboard	4
Work Tool and Arrangements	5
Operator Environment	6
Safety Features	7
Engine and Powertrain	8
Hydraulic Configuration	9
Product Features	10
Customer Support	12
Sustainability	12
Maintenance and Serviceability	13
Technical Specifications	14
Machine Dimensions	16
Standard and Optional Equipment	17
Your Notes	18



EG20 DESIGNED STRENGTH AND DURABILITY.

Frame provides consistency and strength

The front frame is a continuous top and bottom plate structure. Flanged box section design removes welds from high stress areas, improving reliability and durability. The rear frame structure has two box section channels with a fully-welded differential case for a solid working platform. An integrated bumper ties the rear frame together into a cohesive unit to handle high stress loads.

Drawbar, circle and moldboard

The EG20 drawbar is designed for high strength, and increased durability. Raised wear surfaces prevent circle teeth wear against the drawbar.

The 64 uniformly spaced circle teeth are induction hardened to resist wear, and the circle is secured to the drawbar by four support shoes for maximum support. The standard circle drive slip clutch protects your pinion drive and circle teeth from potential damage.

The blade lift cylinder accumulators assist in reducing blade bounce, stress and damage to the blade components.

The moldboard provides optimal curvature and large throat clearance that helps move all soil types quickly and efficiently. These features deliver excellent load distribution and minimal material buildup in the circle area while allowing large blade loads to roll freely.



Blade float

The EG20 is a much heavier machine than the UG20K, providing improved traction and downward pressure to the blade. Standard blade float reduces unnecessary cutting edge wear by allowing the blade to move freely under its own weight. By floating both cylinders, the blade can follow the contours of the ground. Floating only one cylinder permits the toe of the blade to follow a hard surface while you control the slope with the other lift cylinder.

Moldboard

The standard moldboard length is 12' (3700mm). This may be reduced to 10' (3100mm) for underground applications (optional).



IMPROVED VERSATILITY AND PERFORMANCE.

Ground engaging tools

A wide variety of cutting edges and end bits are available, all designed for maximum service life and productivity.

Rear ripper

The EG20 optional ripper is made to penetrate tough material fast and rip thoroughly for easier material movement with the moldboard. The ripper includes three shanks with the ability to add two more if needed. The ripper is listed as optional equipment and is factory fitted prior to dispatch.

Front mounted groups

A front mounted push plate/counterweight is standard equipment or a front blade can be ordered.

Front and rear tow points

Both front and rear tow points are painted red and are categorised as standard equipment. A tow point is optional on the ripper.

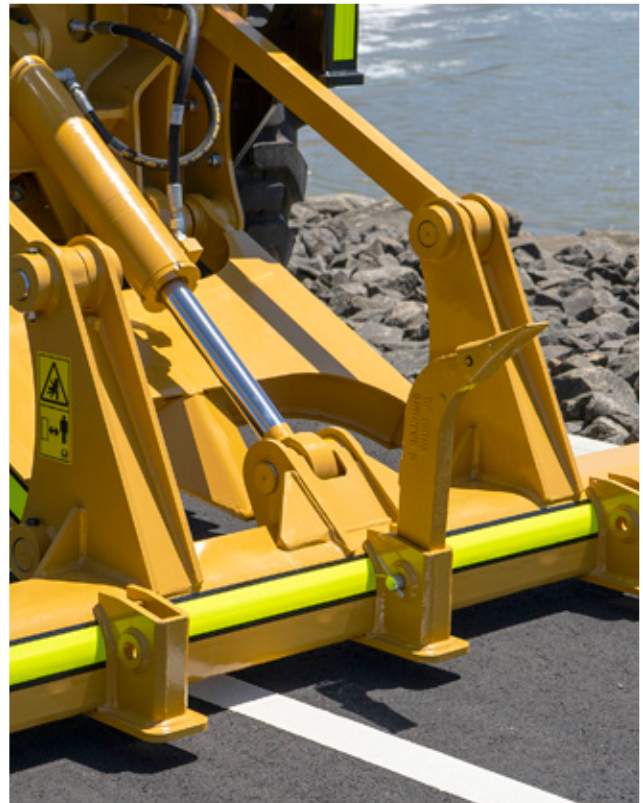



ERGONOMICALLY DESIGNED FOR ALL-DAY COMFORT.

Designed for increased productivity and visibility

The EG20 enclosed cab has been redesigned to improve ergonomics, machine control, and visibility. Features like low-effort pedals and adjustable implement controls and seats provide a comfortable work environment.

Improvements to cab ergonomics include:

- ▶ Improved leg room across the spine is less intrusive making the cab entry and exit much easier.
- ▶ Improved operator seat adjustability and travel.
- ▶ Steering wheel and lever control adjustment (sliding back and forth) plus improved pedal position.
- ▶ Dashboard and camera screens positioned directly in front of the operator and larger foot well windows provide increased blade visibility.
- ▶ Re-positioning of the machine dash cluster directly in front of the operator improving warning response times.
- ▶ Redesigned handrails provide comfortable and easy access to 3 points of contact.

Highly visible in-dash instrument cluster

The instrument panel, with easy-to-read, high-visibility gauges and warning lamps, places vital machine information and diagnostic capability in view of the operator. The instrument cluster includes gauges for engine coolant and hydraulic oil temperature, articulation, fuel level, speedometer, tachometer,



and an hour meter. Working in the dark is easier with backlit transmission shifter and rocker switches.

Elphinstone interlock system

The interlock system prevents the machine from uncontrolled rolling while in neutral. Other features include door interlocks and operator presence which prevent the park brake from being released if cabin doors are open or the seat belt remains unfastened. The park brake will automatically reengage if operator control inputs are not detected within a certain period.

Additional cab features

Cab features include additional storage areas, including a cupholder on left-hand side of the cab. The air conditioning (HVAC) system dehumidifies and pressurises the cab, circulates fresh air, removes dust, and prevents the windows from fogging.



SAFETY FEATURES



MACHINE SAFETY IS THE FIRST PRIORITY.

ROPS/FOPS Cab

The Roll Over Protection System (ROPS) or Falling Object Protection System (FOPS) cab provides a safe and quiet environment with low vibration levels reducing fatigue so the operator remains efficient, productive and safer all day.

LED light package reduces shadowing

Dark becomes light with a full LED light package (Tier 4 only), minimising intense shadows while providing a safe work environment. Tier 3 comes standard with 2x Halogen reverse lamps. The reversing camera (optional) provides the operator with a wide-angle view behind the grader, relaying vision to a screen in the cab, improving operation awareness.

Electrical disconnect and engine shutoff switches

The disconnect switch provides ground-level lockout of the electrical system to prevent inadvertent machine starts. Engine shutoff allows anyone nearby to shut the machine down in case of an emergency.

Stop safely with secondary steer

If the engine should unexpectedly stall, and the main pump pressure should drop, the secondary steering system will turn on automatically to steer safely to a stop.

Hydraulic brake system

The hydraulic brake system and accumulators, compliant with SABS 1589 and fitted as standard, are located at each tandem wheel offering the largest total brake surface area in



the industry. The brakes deliver dependable stopping power and longer brake life.

Additional safety features:

- ▶ Door and seat belt park brake interlocks with visual and audible detection alarms.
- ▶ Automatic fire suppression system (optional).
- ▶ Seat belt cutter.
- ▶ Robust rear guard and wheel chocks.
- ▶ Emergency stops located at ground level and inside the cab.
- ▶ Front counterweight for machine balance.
- ▶ 4 Pole isolators.
- ▶ All handrails and steps painted green.



ENGINE ARRANGEMENT

MAXIMUM POWER AND EFFICIENCY.

Power management

The EG20 has been upgraded with the C7.1 Tier 3 engine arrangement as the standard fit.

The C7.1 ACERT Tier 3 engine arrangement rated at 97-116 kW (132-156 hp) is standard for regions that may not have Ultra Low Sulphur Fuel or more stringent emission regulations. An optional diesel particulate filter can be fitted.

The C7.1 ACERT Tier 4 Final engine arrangement is available as an option, adhering to EU Stage V exhaust emission standards. This arrangement is rated at 104-123kW (140-164 hp).

The Cat C7.1 uses Caterpillar's breakthrough ACERT™ Technology to meet exhaust emission reduction standards. It features efficient fuel delivery, air management and electronic control for high productivity and exceptional service life.

Utilising the CAT 120 base platform, the EG20 features larger more robust tandems, chains and sprockets than the UG20K, enhancing performance, speed potential, stability, and control.

Variable Horse Power (VHP) Plus is standard providing more power in the higher gears.

The electronic throttle control provides easier, more precise and consistent throttle operation. Engine over-speed protection prevents downshifting until an acceptable safe travel speed has been established.

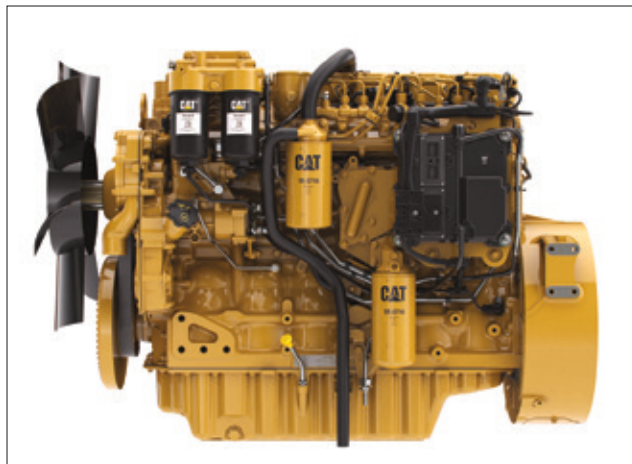

POWER TRAIN

RELIABLE PERFORMANCE.

Smooth shifting transmission

- ▶ Full electronic clutch pressure control ensures smooth shifting and directional changes.
- ▶ Shift torque management helps to smooth gear changes without the use of the inching pedal, helping the operator to remain focused on the task at hand.
- ▶ Load compensation ensures consistent shift quality regardless of blade or machine load.
- ▶ Optional autoshift automatically shifts the transmission at optimal points for easier operation.
- ▶ All power train components are specifically designed to be rebuilt.

Oil disc brakes completely sealed, adjustment free

Oil-bathed, hydraulically-actuated and spring-released, located at each tandem wheel to eliminate power train braking loads and to reduce service time. The large brake surface area provides dependable braking capability and extended life before rebuild.

Front axle with Cat live spindle design

Cat sealed spindle keeps the bearings free from contaminants and lubricated in a lightweight oil to reduce owning and operating costs. A larger tapered roller bearing is outboard where the load is greater, extending bearing life.

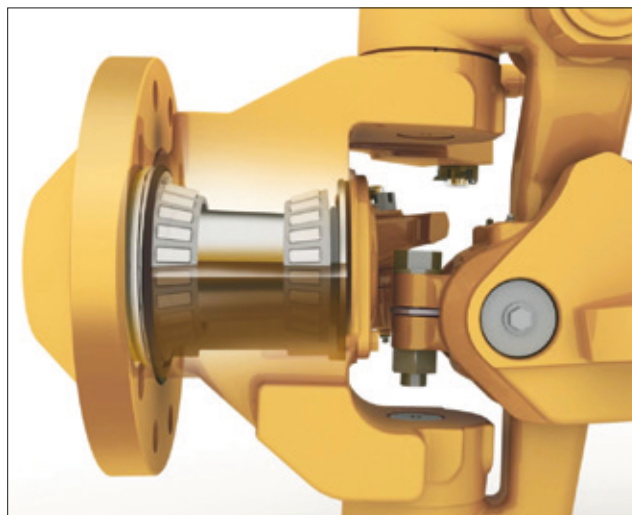



DELIVERING POWER AND CONTROL.

Balanced flow, independent oil supply

Hydraulic flow is proportioned to ensure all implements operate simultaneously. Independent oil supply prevents cross-contamination and provides proper oil cooling, which means less heat build-up and extended component life.

Implement control valves

Provide outstanding operator "feel" and predictable system response for unmatched implement control. To help maintain exact blade settings, lock valves are built into all control valves. Line relief valves are also incorporated into selected control valves to protect the cylinders from over pressurization.

Load-sensing hydraulics

A load sensing variable displacement pump and advanced hydraulic valves provide superior implement control and better machine performance. Continuously matching hydraulic flow and pressure to power demands creates less heat and reduces power consumption.

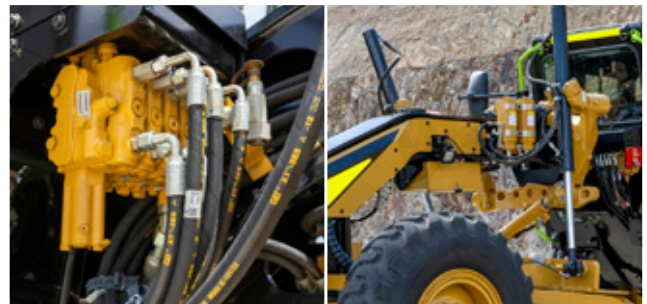

Consistent and predictable movement

The hydraulic system valves are specifically designed for each hydraulic function on the motor grader.

They compensate for differences in flow requirements, based on cylinder size and the difference in surface volume between the rod end and barrel end of the cylinder.

The result is predictable, consistent hydraulic speeds whether extending or retracting the cylinder.



FEATURE OVERVIEW

DESIGNED FOR STRENGTH, COMFORT AND INCREASED PRODUCTIVITY

● Standard ● Optional ● Safety

FRONT COUNTERWEIGHT PUSH BLOCK

Front counterweight/push-block ensures adequate machine balance and steering, particularly with shortened frame

WHEEL CHOCKS

2x chocks stored in brackets either side of the front counterweight

LED LIGHT ARRANGEMENT

Operational and turning indicators

LIVE SPINDLE FRONT AXLE DESIGN

FRONT RETRIEVAL POINT

Painted red

REDUCED HEIGHT MOLDBOARD CYLINDERS

AUTOMATIC LUBRICATION SYSTEM

Centrally manage and automatically apply lubrication to all pivot points and bearings on the machine

SHORTENED GRADER WHEELBASE

Includes shortening the frame and moldboard drawbar

6x LED ADDITIONAL

For optimal lighting

3-PIECE WHEEL RIMS

- STANDARD 12 ft MOLDBOARD
- SHORTENED 10 ft MOLDBOARD

CENTRE SHIFT LOCK GUARD

Protects the centre shift pin mechanism

AUTOMATIC FIRE SUPPRESSION SYSTEM

Manual activation in cabin

ROPS/FOPS ENCLOSED CABIN

Low profile ROPS/FOPS enclosed cabin with air conditioning and pressurisation

HIGH VISIBILITY GREEN HANDRAILS

MULTIVIEW CAMERA

Color 7" LCD display with 2x 118° cameras mounted low on the front of the cab and a 118° reverse camera at the rear

8x ADDITIONAL LED WORK LIGHTS

Appropriate for underground operation
2x below the cabin facing forward
2x facing rearwards and 4x mounted on the front frame facing forwards

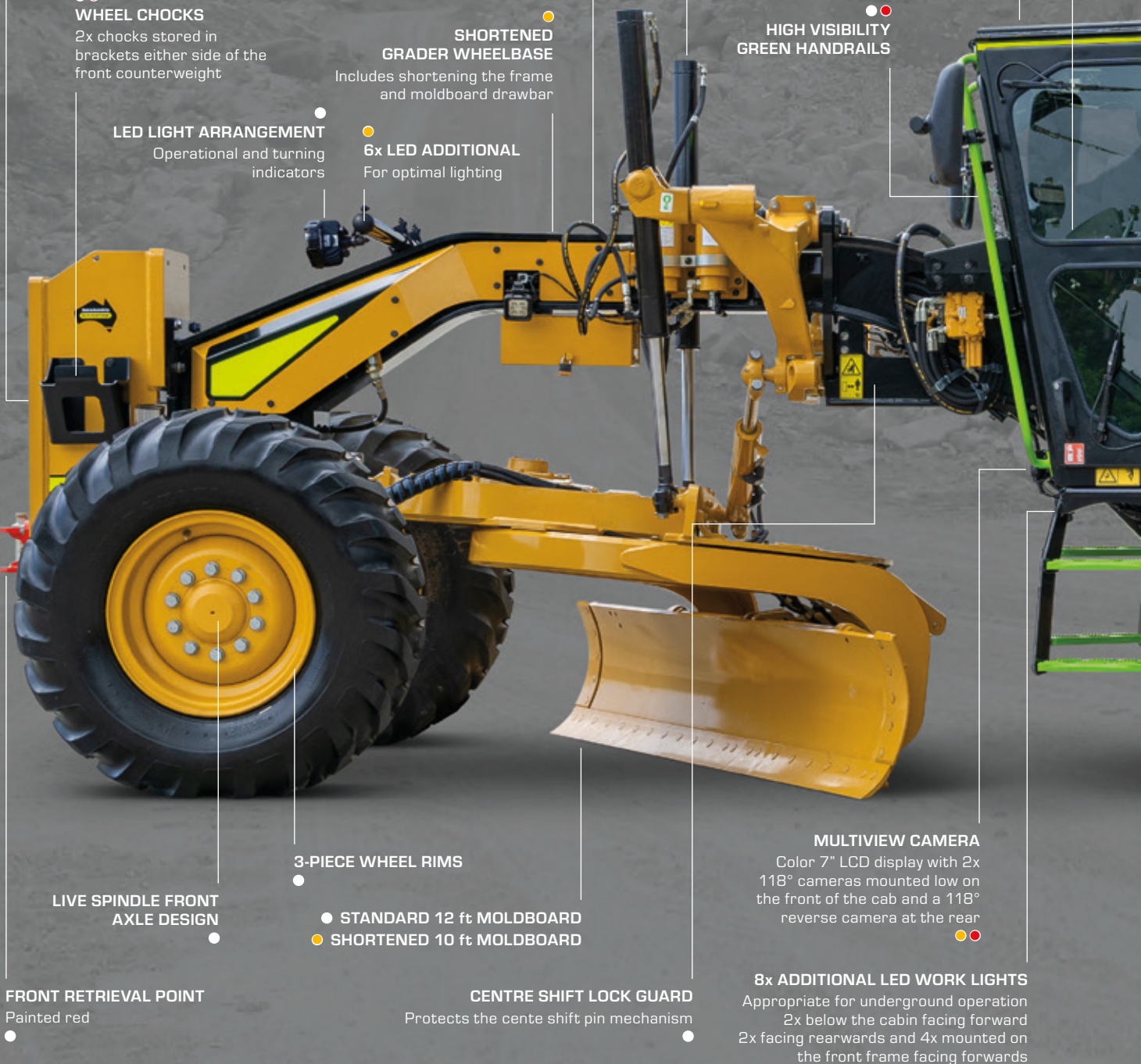

OPERATOR STATION

Features conventional steering wheel and lever hydraulic implement controls and easy to read in-dash instrument cluster

EMERGENCY GP-BRAKE

Automated actuation of the park brake when E-Stop is applied plus additional switch to park brake application

HIGH SPEED FLUID EXCHANGE

Fast-changing of fluids

PRODUCT LINK

EMERGENCY STOP

Red button accessible from within the operator station

HIGH VISIBILITY GREEN STEPS

Visually identifies the access points to safely board or step off the machine

REDUCED HEIGHT EXHAUST OUTLET AND AIR INTAKE

DPF EXHAUST

AXLE BREATHER EXTENSION

DIESEL TOP FILL

TURNING INDICATORS AND STOP (BRAKE) LIGHTS

EMERGENCY STOP

Red button accessible from LHS at ground level - RHS is optional

COMPLETE CAT POWERTRAIN

Proven Cat C7 TIER 2 engine certified to with Bharat Stage III and China Stage II emissions standards, power-shift countershaft transmission, 8 forward / 6 reverse gears for optimal productivity, differential lock and oscillating tandem (chain) drive system

MACHINE ISOLATION

Ground level

DIESEL FAST FILL SYSTEM

Fast and accurately filling of machine every time from the safety of the ground. Environmentally friendly by eliminating overfilling of tank

AUTOMATIC FIRE SUPPRESSION SYSTEM

Pre-engineered dry chemical fire suppression system which is distributed through 6 fixed nozzles located throughout the engine compartment

REVERSE CAMERA

ROTATING BEACON

Rotating beacon located at rear, front or both

EMERGENCY STOP

Red button accessible from LHS at ground level - RHS is optional

SPLASH FILL

Ground level

RIPPER READY

Factory fit

REAR RETRIEVAL POINT

Painted red

REAR RADIATOR PROTECTION GUARD

Reflective tape delineation of the machine profile





CUSTOMER SUPPORT

WHEN UPTIME REALLY COUNTS.

Renowned Cat dealer support

From helping you choose the right machine to financing and ongoing support, your Cat dealer provides the best in sales and service.

- ▶ Manage your costs with preventive maintenance programs like SOS™ fluids analysis, coolant sampling.
- ▶ Stay productive with best-in-class parts availability.
- ▶ our Cat dealer can also help you boost efficiency with operator training.
- ▶ When it's time for component replacement, your Cat® dealer can help you save even more. Genuine Cat® remanufactured parts carry the same warranty and reliability as new products at savings of 40 to 70 percent for powertrain and hydraulic components.
- ▶ Technical training and maintenance planning are also part of the Dealer offerings.
- ▶ Would you like the dealer to do more? Programs such as Customer Service Agreements (CSA), to a full maintenance and repair contract are available.
- ▶ The EG20 Grader contains >90% Genuine Cat® Parts.



FUTURE SUSTAINABILITY

THINKING INTO THE FUTURE.

Elphinstone machines are produced in Tasmania, Australia where our facilities operate on 100% renewable energy.

Sustainable waste and cost management

- ▶ Integrated machine systems and technologies improve productivity for greater accuracy, lower fuel use and reduce machine wear.
- ▶ Replaceable wear parts save maintenance time and cost and extend major component life.
- ▶ Ecology drains help make draining fluids more convenient and help prevent spills.
- ▶ Major components are built to be rebuilt, eliminating waste and saving customers money by giving the machine and/or major components a second – and even third life rebuilds.
- ▶ A variety of safety features help safeguard operators and others on the job.

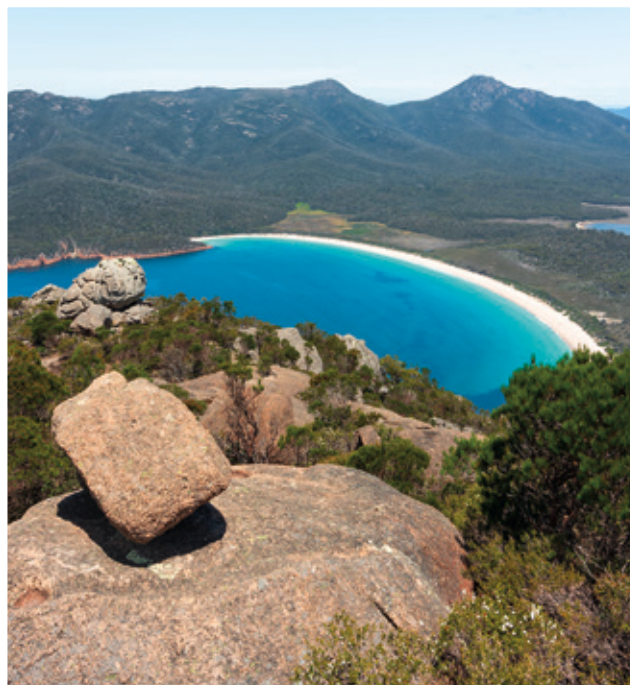



SERVICEABILITY MEANS MORE TIME FOR PRODUCTION.

Maintenance and accessibility

Easy access to service areas speeds up maintenance and ensures that routine services are completed on time.

Service and maintenance made easy:

- ▶ Filters, such as fuel, engine air, and oil filters are grouped together for easy access and preventative maintenance.
- ▶ All major service points are located at ground level.
- ▶ Next generation CAT filters help to reduce filtration costs by approximately 15%.
- ▶ Ecology drains shorten service times and help prevent spills.
- ▶ Fast and accurate fuel fill (splash fill) every time from the safety of the ground. Environmentally friendly by eliminating overfilling of tank.
- ▶ High visibility green grab rails and heavily gripped steps provide 3-points of contact for safe maintenance and service access on both sides of the machine.

Extended service intervals

- ▶ 500 hour engine oil changes.
- ▶ 4,000 hour hydraulic oil changes.
- ▶ 12,000 hour engine coolant changes.

O-Ring face seals

O-Ring face seals create a reliable connection and are used in all hydraulic circuits to minimise the possibility of oil leaks.

Separate wiring harnesses

Modular harness design provides simple disconnects for major machine repairs or rebuilds which reduces machine downtime.

Product Link™ and machine diagnostics

Product Link™ PLE641 gathers hours, location, fuel usage, productivity, idle time, maintenance alerts, diagnostic codes, and machine health and can be viewed online through web and mobile applications. It comes with an internal antenna (optional external antenna available). PLE641 Flash-Over-The-Air (FOTA) and also supports Remote Services when combined with Network Manager PLE601.

The dash cluster panel provides enhanced machine information and diagnostic capability, which allows faster servicing of the transmission and engine.

Cat electronic technician (Cat ET)

Cat Electronic Technician is a two-way communication tool that gives service technicians easy access to stored diagnostic data, reducing machine downtime and operating costs.

Circle Saver™ (Cat option)

The easy-to-access Circle Saver grease kit allows you to keep the circle drive pinion greased at all times. Circle Saver features a remote fitting and grease line that runs from the drawbar to the pinion housing (aka bucket) making it easier for you to grease the pinion from the top of the drawbar instead of underneath the circle.



TECHNICAL SPECIFICATIONS

Engine - Tier 3/Stage IIIA Equivalent

Engine Model	Cat C7.1	
Emissions	Brazil MAR-1 emission standards, U.S. EPA Tier 3 and EU Stage IIIA equivalent	
Base Net Power ISO 9249/SAE J1349	97 kW	130 hp
Base Net Power EEC 80/1269 (metric)	132 hp	
Power Range - Net	97-116 kW	130-156 hp
Power Range - Net (metric)	132-158 hp	
Bore	105 mm	4.1 in
Displacement	7.01 L	427.8 in ³
Stroke	135 mm	5.3 in
Engine RPM	2,000	
Number of Cylinders	6	
Torque Rise - ISO 9249	42%	
Maximum Torque - ISO 9249	822 N-m	606 lb-ft
Derating Altitude	4500 m	14,764 ft
Maximum - Fan Speed	1,300 rpm	
Minimum - Fan Speed	600 rpm	
Ambient Capacity	50° C	122° F

» Cat engines are compatible with diesel fuel blended with the following lower-carbon intensity fuels up to:

- 100% biodiesel FAME (fatty acid methyl ester)*
- 100% renewable diesel, HVO (hydrotreated vegetable oil) and GTL (gas-to-liquid) fuels

» Refer to guidelines for successful application. Please consult your Cat dealer or "Caterpillar Machine Fluids Recommendations"

» (SEBU6250) for details.

*For use of blends higher than 20% biodiesel, consult your Cat dealer.

EG20 Net Power - Tier 3/Stage IIIA Equivalent

Gear	kW (hp)
Forward	
1st	97 (130)
2nd	97 (130)
3rd	101 (136)
4th	108 (145)
5th	112 (150)
6th	116 (156)
7th	116 (156)
8th	116 (156)
Reverse	
1st	97 (130)
2nd	97 (130)
3rd-6th	101 (135)

Engine - Tier 4 Final/Stage V

Engine Model	Cat C7.1	
Emissions	U.S. EPA Tier 4 Final/ EU Stage V	
Base Net Power ISO 9249/SAE J1349 EEC 80/1269	104 kW	140 hp
Base Net Power ISO 9249/SAE J1349 EEC 80/1269 (metric)	142 hp	
Power Range - Net	104-123 kW	140-164 hp
Power Range - Net (metric)	142-167 hp	
Bore	105 mm	4.1 in
Displacement	7.01 L	427.8 in ³
Stroke	135 mm	5.3 in
Engine RPM	2,000	
Number of Cylinders	6	
Torque Rise - ISO 9249	42%	
Maximum Torque - ISO 9249	822 N-m	606 lb-ft
Derating Altitude	3000 m	9,842 ft
Maximum - Fan Speed	1,300 rpm	
Minimum - Fan Speed	600 rpm	
Ambient Capacity	50° C	122° F

» Cat diesel engines are required to use ULSD (ultra-low sulfur diesel fuel with 15 ppm of sulfur or less) or ULSD blended with the following lower-carbon intensity fuels up to:

- 20% biodiesel FAME (fatty acid methyl ester).*
 - 100% renewable diesel, HVO (hydrotreated vegetable oil) and GTL (gas-to-liquid) fuels. Refer to guidelines for successful application. Please consult your Cat dealer or "Caterpillar Machine Fluids Recommendations" (SEBU6250) for details.
- *Engines with no after treatment devices can use higher blends, up to 100% biodiesel (for use of blends higher than 20% biodiesel, consult your Cat dealer).

» Net Power is tested per ISO 9249, SAE J1349, and EEC 80/1269 Standards in effect at the time of manufacture.

» Net power advertised is the power available at rated speed of 2,000 rpm, measured at the flywheel when engine is equipped with fan, air cleaner, muffler, and alternator.

» VHP Plus is standard for the EG20.

» Rated speed at 2,000 rpm.

» Biodiesel blends up to B30 (30% blend by volume) are acceptable when blended with 500 ppm (mg/kg) sulfur or less ULSD. B30 should meet ASTM D7467 specification (biodiesel blend should meet Cat biodiesel spec, ASTM D6751 or EN 14214). Cat DEOULS™ or oils that meet the Cat ECF-3, API CJ-4, and ACEA E9 specification are required. Consult your OMM for further machine specific fuel recommendations.

EG20 Net Power - Tier 4 Final/Stage V

Gear	kW (hp)
Forward	
1st	104 (139)
2nd	107 (143)
3rd	110 (148)
4th	119 (160)
5th	123 (165)
6th	123 (165)
7th	123 (165)
8th	123 (165)
Reverse	
1st	104 (139)
2nd	107 (143)
3rd-6th	110 (148)



TECHNICAL SPECIFICATIONS

Powertrain

Forward/Reverse Gears	8 Forward/6 Reverse
Transmission	Direct Drive, Power Shift
High Idle Speed	2,000 rpm
Low Idle Speed	
Tier 3	800 rpm
Tier 4	1,030 rpm
Air Cleaner	Dry

Hydraulic System

Type	Closed – Centre
Type Circuit	Parallel
Pump Type	Variable Displacement Piston
System Pressure	24 129 kPa 3500 psi
System Flow	0-200 L/min 0-53 gal/min

Operating Specifications

Top Speed Forward	48.3 km/h	30.1 mph
Top Speed Reverse	38.1 km/h	23.7 mph
Turning Radius, Outside Front Tyre	Refer to machine diagrams	
Steering Range, Left/Right	50 Deg.	
Articulation Angle, Left/Right	20 Deg.	
Front Wheel Lean, Left/Right	18 Deg.	
Total Oscillation	32 Deg.	
Forward		
1st	4.1 km/h	2.6 mph
2nd	5.6 km/h	3.5 mph
3rd	8.2 km/h	5.1 mph
4th	11.3 km/h	7.0 mph
5th	17.7 km/h	11 mph
6th	24.1 km/h	15.0 mph
7th	33.2 km/h	20.6 mph
8th	48.3 km/h	30.1 mph
Reverse		
1st	3.3 km/h	2.0 mph
2nd	6.1 km/h	3.8 mph
3rd	8.9 km/h	5.5 mph
4th	14.0 km/h	8.7 mph
5th	26.2 km/h	16.3 mph
6th	38.1 km/h	23.7 mph

» Machine speed measured at 2,150 rpm with 14.00R24 radial tires, no slip.

Tandems

Tandem Oscillation	
Front Up	15 Deg.
Front Down	22 Deg.

Moldboard

Width - Standard	3700 mm	12 ft
Width - Optional	3048 mm	10 ft
Height	610 mm	24 in
End Bit	152mm	6 in
Cutting Edge	152 mm	6 in
Arc Radius	413 mm	16.3 in
Throat Clearance	120 mm	4.7 in
Blade Pull - Base GVW	9,266 kg	20,429 lb
Blade Pull - Maximum GVW	12,402 kg	27,341 lb
Blade Down Force - Base GVW	6,311 kg	13,914 lb
Blade Down Force - Maximum GVW	10,895 kg	24,019 lb

» Moldboard Pull calculated at 0.9 traction coefficient, which is equal to ideal no-slip conditions, and Gross Vehicle Weight (GVW).

Drawbar Circle Moldboard

Centreshift			
Right	656 mm	25.8 in	
Left	656 mm	25.8 in	
Sideshift / 12' Moldboard			
Right	660 mm	26 in	
Left	510 mm	20.1 in	
Sideshift / 10' Moldboard			
Right	355 mm	13.9 in	
Left	205 mm	8 in	
Blade Tip Range			
Forward	40 Deg.		
Backward	5 Deg.		
Maximum Shoulder Reach Outside of Tyres			
Wheelbase / Blade Length	Left	Right	
Standard /12'	1742 mm	68.6 in	1905 mm 75 in
Standard /10'	1160 mm	45.6 in	1220 mm 48 in
Shortened /12'	1690 mm	66.5 in	1730 mm 68.1 in
Shortened /10'	1080 mm	42.5 in	1120 mm 44 in
Maximum Depth of Cut	775 mm		30.5 in
Maximum Lift Above Ground	410 mm		16.1 in

Circle

Section	Rolled Ring Forging
Number of Teeth	64
Rotation	360 Deg.

Service Refill Capacities

Fuel Tank	246 L	65 gal
Circle Drive Housing	7 L	1.8 gal
Engine Oil	18 L	4.8 gal
Cooling System	52.5 L	14 gal
Hydraulic System	97 L	25.6 gal
Diesel Exhaust Fluid Tank (Tier 4 only)	11 L	2.9 gal
Transmission / Differential	60 L	15.8 gal
Tandem Housing (each)	60 L	15.8 gal



TECHNICAL SPECIFICATIONS

Weights - Tier 3/Stage IIIA Equivalent

Gross Vehicle Weight, Base		
Total	13,899 kg	30,642 lb
Front Axle	3,603 kg	7,943 lb
Rear Axle	10,296 kg	22,698 lb
Gross Vehicle Weight, Typically Equipped*		
Total	15,803 kg	34,839 lb
Front Axle	4,359 kg	9,610 lb
Rear Axle	11,444 kg	25,229 lb

Weights - Tier 4 Final/Stage V

Gross Vehicle Weight, Base		
Total	14,272 kg	31,464 lb
Front Axle	3,564 kg	7,856 lb
Rear Axle	10,708 kg	23,608 lb
Gross Vehicle Weight, Typically Equipped*		
Total	16,271 kg	35,871 lb
Front Axle	4,372 kg	9,637 lb
Rear Axle	11,899 kg	26,234 lb

» Base weight calculated on standard machine configuration with 14.0R24 12PR (G-2) tyres, SP rims, full fuel tank, coolant, lubricants and operator.

» *Typically equipped includes 3.7 m (12') blade, 14.00R24 tires, push plate, ripper, bottom guard, operator, and full fluids.

Standards

ROPS/FOPS	ISO 3471:2008 / ISO 3449:2005 level II
Steering	ISO 5010:2007
Brakes	ISO 3450:2011

Service Brakes

Type System	Dual Circuit Hydraulic	
Type Brake	Multiple Oil Disc	
Number of Brakes	4	
Number of Disc Assemblies (each)	6	
Size (outer diameter)	270 mm	10.6 in
Size (inner diameter)	189 mm	7.4 in
Lining Area Per Brake	3504 cm ²	543.1 in ²

Park Brakes

Type System	Hydraulic Actuated
Type Brake	Multiple Oil Disc, Meets ISO 3450
Slope Holding Ability	30 Deg.
Secondary Brakes	Dual Circuit Control System, Applies Two Service Brakes

Electrical

Starting System Type	Direct Electric
Heavy Duty Battery	
- CCA at -18 Deg	1,125 amp
- Volts	12V
- Quantity	2
Standard Alternator	115 amps at 24V

Ripper*

Ripping Depth Maximum	288 mm	11.2 in
Ripper Shank Holder	5	
Ripper Shank Holder Spacing	533 mm	20.8 in
Penetration Force	5119 kg	11,287 lb
Pryout Force	2029 kg	4,473 lb
Machine Length Increase, Beam Raised	900 mm	35.1 in

*Ripper is a factory fit option.



MACHINE DIMENSIONS SHORTENED WHEELBASE

Turning Radius

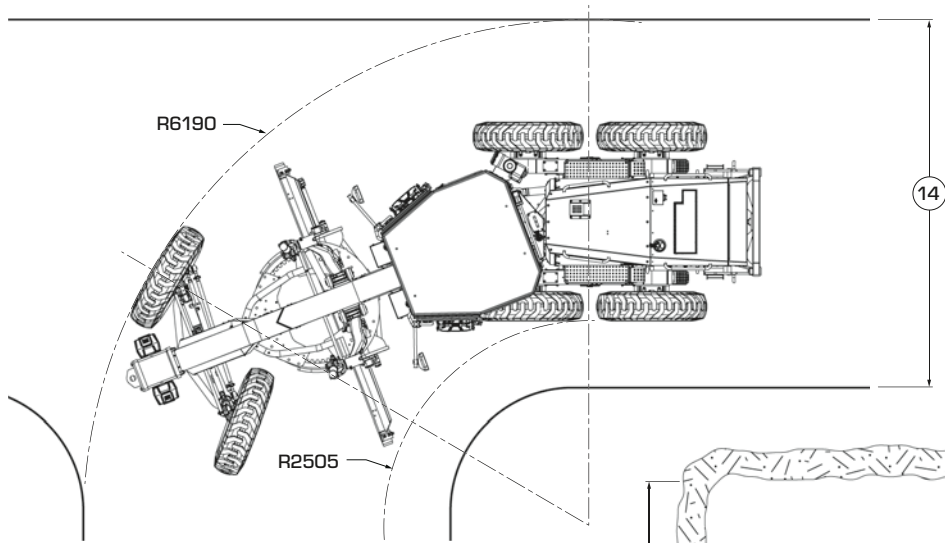

Side View and Drive Size

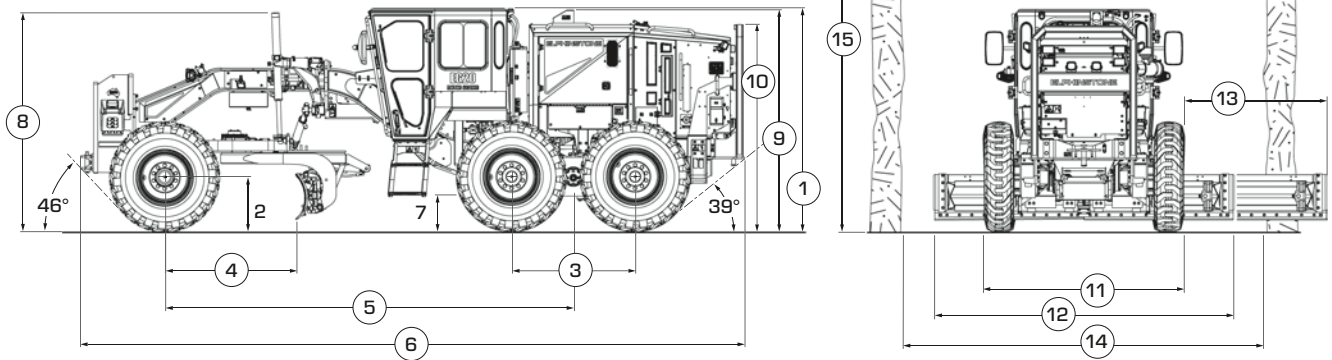

Dimensions

All dimensions are based on 14.OOR24 tyres. *Ripper is a factory fit option.

1	Height - Top of Cab	2650 mm	8 ft 8.3 in
2	Height - Front Axle Centre	590 mm	1 ft 11.2 in
3	Length - Between Tandem Axles	1510 mm	4 ft 11.4 in
4	Length - Front Axle to Moldboard	1600 mm	5 ft 3.0 in
5	Length - Front Axle to Mid Tandem	5000 mm	16 ft 4.9 in
6	Length - Counterweight to Rear of Machine Length - Counterweight to Ripper*	8115 mm 9035 mm	26 ft 7.5 in 29 ft 7.7 in
7	Ground Clearance - Transfer Case	400 mm	1 ft 3.7 in
8	Height - Top of Cylinders	2590 mm	5 ft 6.0 in
9	Height - Exhaust Stack	2625 mm	8 ft 7.3 in
10	Height - Top of Rear Guard	2445 mm	8 ft 0.3 in
11	Width - Outside Rear Tyres Width - Outside Front Tyres	2440 mm 2470 mm	8 ft 0.1 in 8 ft 1.2 in
12	Width - Moldboard Standard Width - Moldboard Optional	3700 mm 3048 mm	12 ft 1.7 in 10 ft
13	Maximum Reach, Standard 12 ft Moldboard	1905 mm	6 ft 3.0 in

Drive Size

14	Minimum Width Portal (90° corner)	4500 mm	14 ft 9.2 in
15	Typical Minimum Height Portal	4500 mm	14 ft 9.2 in

*Measurements subject to change



MACHINE DIMENSIONS STANDARD WHEELBASE

Turning Radius

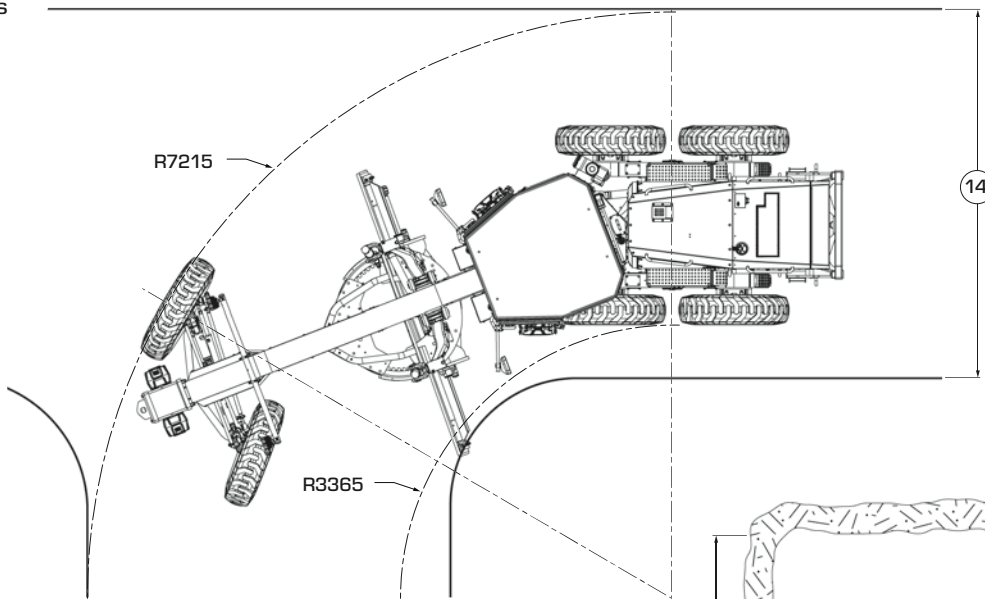

Side View and Drive Size

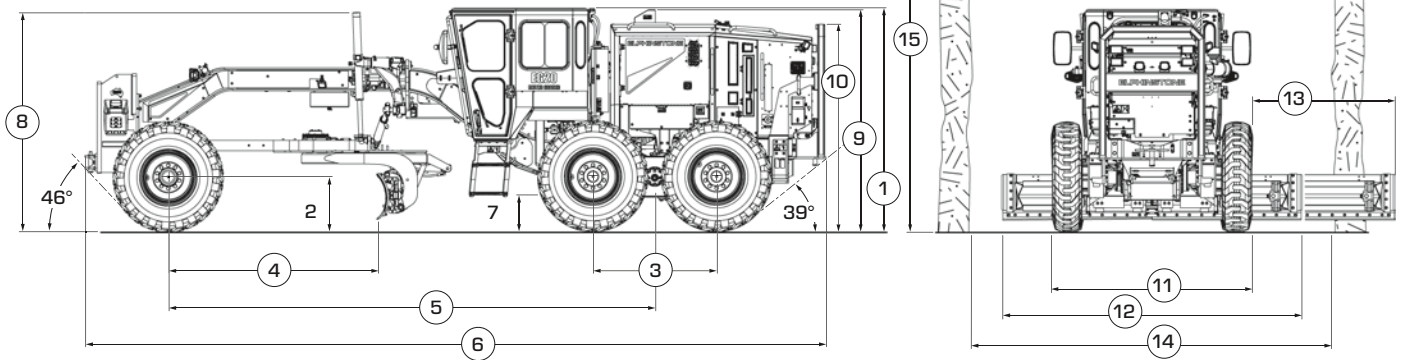

Dimensions

All dimensions are based on 14.OOR24 tyres. *Ripper is a factory fit option.

1	Height - Top of Cab	2650 mm	8 ft 8.3 in
2	Height - Front Axle Centre	590 mm	1 ft 11.2 in
3	Length - Between Tandem Axles	1510 mm	4 ft 11.4 in
4	Length - Front Axle to Moldboard	2545 mm	8 ft 4.2 in
5	Length - Front Axle to Mid Tandem	5945 mm	19 ft 6.1 in
6	Length - Counterweight to Rear of Machine Length - Counterweight to Ripper*	9060 mm 9980 mm	29 ft 8.7 in 32 ft 8.9 in
7	Ground Clearance - Transfer Case	400 mm	1 ft 3.7 in
8	Height - Top of Cylinders	2590 mm	5 ft 6.0 in
9	Height - Exhaust Stack	2625 mm	8 ft 7.3 in
10	Height - Top of Rear Guard	2445 mm	8 ft 0.3 in
11	Width - Outside Rear Tyres Width - Outside Front Tyres	2440 mm 2470 mm	8 ft 0.1 in 8 ft 1.2 in
12	Width - Moldboard Standard Width - Moldboard Optional	3700 mm 3048 mm	12 ft 1.7 in 10 ft
13	Maximum Reach, Standard 12 ft Moldboard	1905 mm	6 ft 3.0 in

Drive Size

14	Minimum Width Portal (90° corner)	4500 mm	14 ft 9.2 in
15	Typical Minimum Height Portal	4500 mm	14 ft 9.2 in

*Measurements subject to change



STANDARD AND OPTIONAL EQUIPMENT

● Standard ● Optional ● Safety

Powertrain

Air Cleaner - Dry type radial seal with service indicator and automatic dust ejector	●
Air Cleaner - Dual stage dry type diesel with automatic dust ejector (Tier 4F)	●
Air Cleaner - Dual stage dry type diesel (Tier 3)	●
Air To Air After Cooler (ATAAC)	●
Blower Fan	●
Brakes, Disc, Four Wheel, Hydraulic	●
Differential with Lock/Unlock	●
Engine, Cat C7.1 Tier 3 with ACERT Technology Certified to Brazil MAR-1 emission standards, U.S. EPA Tier 3 and EU Stage IIIA equivalent	●
Engine, Cat C7.1 Tier 4 Final with ACERT Technology Certified to U.S. EPA Tier 4 Final/EU Stage V	●
Fuel Tank, 305 L (80.6 Gal)	●
Fuel Water Separator	●
Muffler, Under Hood	●
Parking Brake, Multi-disc, Seal and Oil Cooled	●
Prescreener	●
Priming Pump, Fuel, Resiliently Mounted	●
Sediment Drain, Fuel Tank	●
Tandem Drive	●
Transmission, 8 speed forward and 6 speed reverse, power shift, direct drive with electronic shift control and overspeed protection	●
VHP (Variable Horse Power)	●

Antifreeze

Coolant, Extended Life for -35°C (-30°F)	●
Coolant, Arctic Extended Life for -50°C (-58°F)	●

Operator Environment

Accelerator	●
Air Conditioning (HVAC) system	●
Cab, ROPS	●●
Camera, Reverse	●●
Control Console, Adjustable	●
Fan, Defroster, Front Window	●
Gauge Cluster, Includes, Engine Coolant and Hydraulic Oil Temperature, Articulation and Fuel Level	●
Guard Rails, Operator Station	●
Hydraulic Controls, Load Sensing (right/left blade lift, circle drive, centreshift, sideshift, front wheel lean and articulation)	●
Indicator lights (includes high beam, LH and RH turn, low engine oil pressure, throttle lock, check engine, transmission filter bypass and check, centreshift pin, low brake pressure, parking brake engaged, auto shift)	●
Key Start / Stop Switch	●
Meter, Hour	●
Mirrors, Outside Mounted	●
Power Steering, Hydraulic	●
Seat Belt, Retractable, 2 Point	●
Seat Belt, Retractable, 2 Point with Occupancy Indicator	●
Seat, Compact Mechanical Suspension, Low Back with Black PVC Trim	●
Steering Wheel, Tilt, Adjustable	●
Storage Area, Cooler/Lunch Box	●
Tachometer/Speedometer	●
Throttle Control	●
Wipers, Intermittent Front	●

Electrical

Alternator, 115 Ampere	●
Backup Alarm, Reversing Lights	●

Electrical

Bar Mounted, Low, Directional and Headlights	●
Batteries, Maintenance Free 750 CCA	●
Electrical System, 24 volt	●
Emergency Stop Switch Cab	●●
Emergency Stop Switch LHS Engine Cowling	●●
Emergency Stop Switch RHS Engine Cowling	●●
Horn, Electric	●
Lights, Stop, Tail	●
Lights, Warning, Beacon, (Amber, Rotating)	●●
Lights, Warning, Beacon, (Blue, Flashing)	●●
Lights, Warning, Beacon, (White, Flashing)	●●
Lights, LED, Working, Cab Mounted, Low	●
Lights, LED, Working, Front, Additional	●
Lights, LED, Working	●
Motor, Starting	●
Product Link, Cellular	●

Work Tools

Moldboard 12 ft Blade, 12 ft x 24 in x 7/8 in (3658 mm x 610 mm x 22 mm) with hydraulic side shift and blade tip. 2 x 6 ft, 6 in x 5/8 in (152 mm x 16 mm) DH2 heat treated cutting edges	●
Moldboard 10 ft Blade, 10 ft x 24 in x 7/8 in (3048 mm x 610 mm x 22 mm) with hydraulic side shift and blade tip. 1 x 6 ft & 1 x 4 ft, 6 in x 5/8 in (152 mm x 16 mm) DH2 heat treated cutting edges	●
End bits, 5/8 in (16 mm) DH-2 Steel	●

Hydraulics

Pump, Hydraulic, Standard 159.1 L/min (42 gal/min)	●
Tank, Reservoir, Capacity 24.5L (6.4 gal)	●
Pump Type, Variable Piston	●

Ripper

Ripper, Machine ready (Factory fit by Elphinstone)	●
Ripper, Factory fit by Elphinstone	●

Guards

Guard, Transmission	●
Rear Guard	●

Other

Automatic Fire Suppression System, Dry Powder	●●
Automatic Fire Suppression System, AFFF	●●
Automatic Fire Suppression System, Ansul LVS	●●
Clutch, Circle Drive, Slip	●
Doors, Engine Compartment	●
Drawbar, 4 Shoe Replaceable Nylon Composite Wear Strips	●
Dryer, Air	●
Film, GP Reflective, Fluorescent Yellow	●●
Frame, Articulated with Safety Lock	●
Link Bar, 7 Position	●
Parts Book, Operation and Maintenance Manual Download	●
Push Plate, Counterweight	●
Retrieval Points	●
Seat Cover (Canvas)	●
SOS SM Ports, Engine, Hydraulic, Transmission and Cooling	●
Steps, Green	●
Security - Including Cap Locks for Hydraulic Tank, Radiator Access Cover, Fuel Tank, Engine and Transmission Oil Check/ Fill and Lockable Battery Boxes	●
Wheel Chocks, Yellow	●●

OVER 45 YEARS IN THE MINING INDUSTRY.

Elphinstone Pty Ltd is an established Caterpillar OEM Solutions customer with over 45 years' experience in the mining industry.

Elphinstone specialises in the design, manufacture and support of quality equipment for the global underground and surface mining industries.

The Elphinstone range of products combines practical design, the latest technology and quality manufacturing to ensure reliable performance.

The current product range includes specialised underground support vehicles, mine extraction devices, extended distance off-highway haulage trucks and water tanks designed to fit Caterpillar 740C, 745C and 745 articulated trucks.

All Elphinstone products, technical assistance, support, and access to spare parts are available through the global Cat® dealer network with additional support from the Elphinstone regional sales and support team.

EG20 MOTOR GRADER

For more complete information on Elphinstone products, dealer services, and industry solutions, visit www.elphinstone.com or contact your local Cat® dealer.

Material and specifications are subject to change without notice. Featured machines in photos may include additional equipment.

Elphinstone and their respective logos, as well as corporate and product identity used herein, are trademarks of Elphinstone and may not be used without permission.

© 2026 Elphinstone. All rights reserved.
Made in Australia for export.

ELPHINSTONE



HM68414-04 (03-2026)