



MED

MINE EXTRACTION DEVICE



Available in 150, 210 and 360 tonne rated capacities

Elphinstone Mine Extraction Device (MED)
elphinstone.com

ELPHINSTONE

UNDERGROUND RELIABILITY



ELIMINATES UNSAFE EXTRACTIONS

Use fit-for-purpose equipment during extractions

The Elphinstone Mine Extraction Device (MED) has been designed, manufactured and engineer certified with a pulling capacity of up to 360 Tonnes.

The Mine Extraction Device was invented in response to requests from underground miners having difficulties extracting buried equipment without damaging the mine or negatively impacting production.

The MED has performed hundreds of successful extractions at a number of underground mining operations (both coal and hard rock) across Australia and internationally.

Minimises disruptions to mining operations

Production disruptions are minimised by eliminating the need to deploy production equipment to assist in recoveries as well as minimising interactions with bogged or buried equipment.

The MED eliminates the need for traditional recovery methods that involve the use of other mobile equipment,

which reduces the hazards associated with personnel working around mobile equipment in close quarters and allows other mining operations to continue relatively uninterrupted.

What makes the MED so unique?

The Mine Extraction Device does not rely on traction like other systems. After the MED is towed into position and the boom is raised against the roof, the wheels are lowered on the floor. A bridle is interlocked onto the teeth of the MED racks. These MED racks are then pulled via hydraulic cylinders.

This is in contrast to using wheeled or tracked tow vehicles that can result in damage to the machines, the mine infrastructure, all of which can add further delays to the restart of production.

Insurance supports the proven MED system

The unique retrieval system has the support of numerous insurance companies with the recognition that if this system cannot retrieve a buried loader then the loader is not retrievable.



PULLER CAPABILITIES & SPECIFICATIONS

Three power-packed levels of pulling capacity

The Mine Extraction Device is available in 150-tonne, 210-tonne, and 360-tonne capacities, developed in line with industry growth.

In addition to the retrieval of buried equipment, the higher capacity models are also capable of extracting drill rods embedded in the rock face.

Features Include:

- » Pulling capacity of up to 360 Tonnes.
- » The extendable boom allows use in a range of underground operations.
- » Easily towed into place.
- » Operating pressure (Max) 180 Bar, flow rate of 6-70 litres per minute.
- » Control pedestal and pilot valve.
- » Optional remote control.
- » Winch to assist rack positioning.
- » Cranes to assist positioning racks (MED360 only)





STANDARD AND OPTIONAL EQUIPMENT

● Standard ● Optional

Description	Qty	MED150	MED210	MED360
Arm Lift Ram Safety Lock	1			●
Base Machine	1	●	●	●
Boom Extension, 4m (13.1 ft)	1	●	●	
Boom Extension, 5m (16.4 ft)	1	●	●	
Boom Extension, 6m (19.6 ft)	1		●	●
Boom Extension, Adjustment Link	1			●
Connecting Link, D-shackle	1	●	●	●
Control Bank	1	●	●	●
Head Plate, Flat	1	●	●	●
Head Plate, Curved	1	●	●	●
Hose Storage Rack	1	●	●	●
Hydraulic Hoses, Machine to Control Bank	10m / 32ft 9.6in	●	●	●
Hydraulic Hoses, Control Bank to Power Pack	10m / 32ft 9.6in	●	●	●
Hydraulic Power Pack	1	●	●	●
Hydraulic Winch	1	●	●	●
Rack, 1000 mm (39.4 in)	10	●	●	●
Rack, 2000 mm (78.7 in)	1	●		
Rack, Pin	10	●	●	●
Rack, Transport box	1	●	●	●
Rack, Lifting Tool	1	●	●	
Shipping Container, 20 foot	1	●	●	
Shipping Container, 20 foot	2		●	●
Tow Bar	1		●	●
Tow Bar, Connection Pin	1		●	●

Operation	MED150	MED210	MED360
Operating Pressure (Max)	180 bar	180 bar	180 bar
Operating Flow Rate	6-70 l/min	6-70 l/min	6-70 l/min

Diagram for reference purposes only

Model pictured: MED210

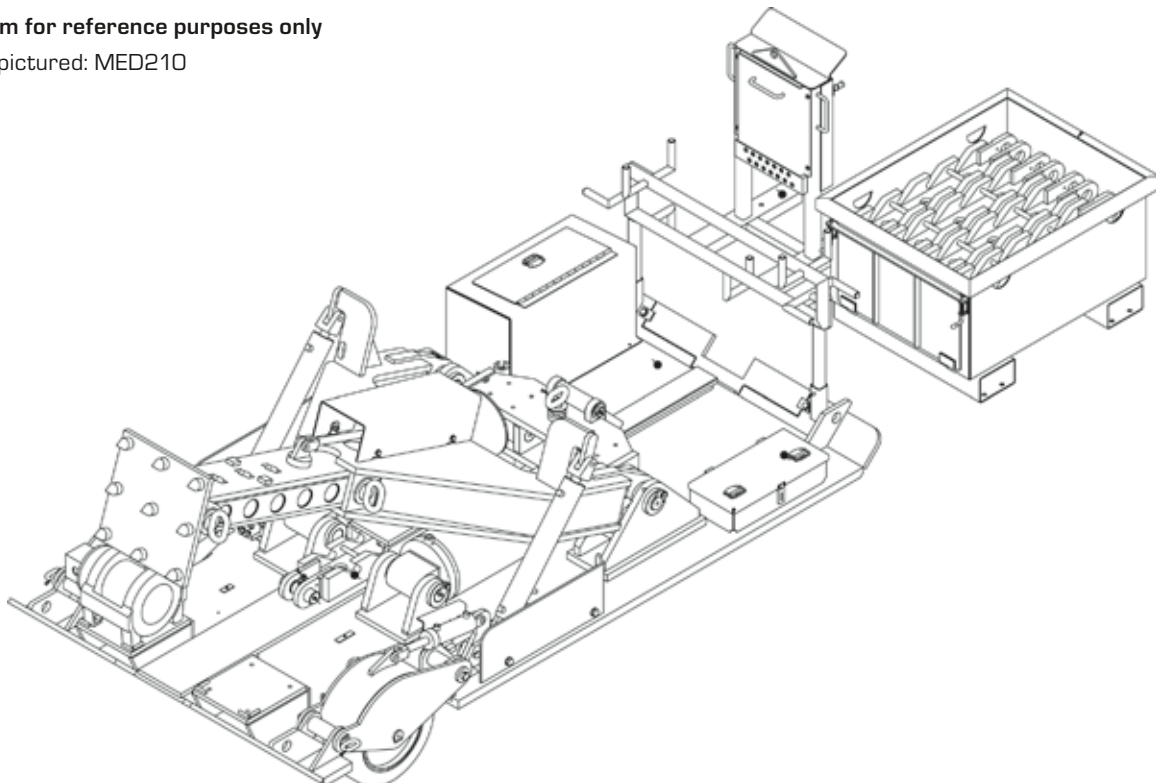
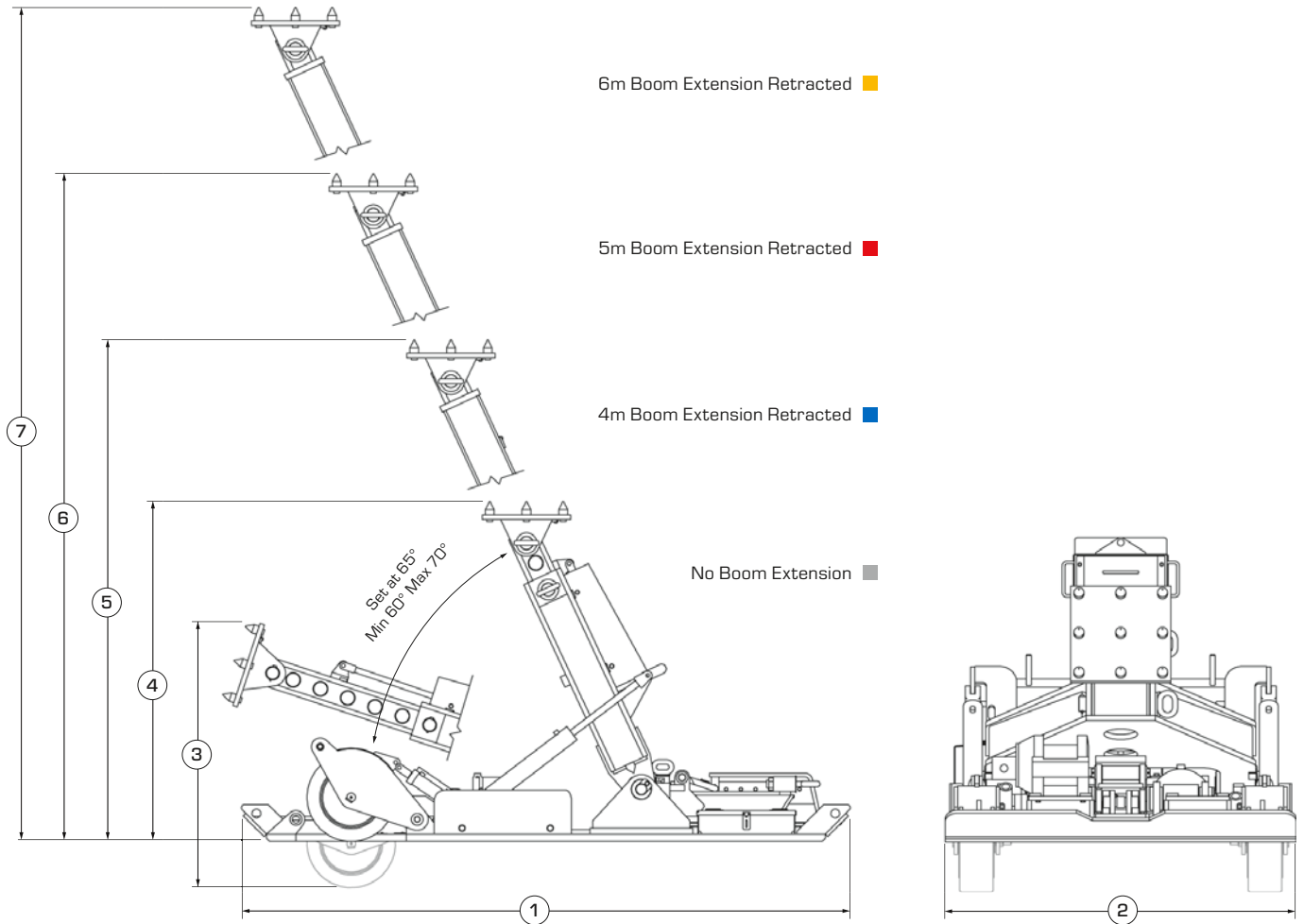



Diagram for Reference Purposes Only



Dimensions		MED150		MED210		MED360	
1	Length	3246 mm	10 ft 7.8 in	4142 mm	13 ft 7.1 in	4720 mm	15 ft 5.8 in
2	Width	1820 mm	5 ft 11.7 in	2100 mm	6 ft 10.6 in	2300 mm	7 ft 6.9 in
3	Height - Ground to Head Plate - Retracted for Transport	1610 mm	5 ft 3.4 in	1830 mm	6 ft	1940 mm	6 ft 4.4 in
4	Height - Retracted (No Boom Extension)	2150 mm	7 ft	2320 mm	7 ft 7.3 in	2800 mm	9 ft 2.2 in
	Height - Extended (No Boom Extension)	3035 mm	9 ft 11.5 in	3030 mm	9 ft 11.2 in	3550 mm	11 ft 7.8 in
5	Height - Retracted with Standard 4m Boom Extension (13.1 ft)	3200 mm	10 ft 6 in	3470 mm	11 ft 4.6 in	3510 mm	11 ft 6.2 in
	Height - Extended with Standard 4m Boom Extension (13.1 ft)	4180 mm	13 ft 8.6 in	4290 mm	14 ft 0.9 in	4550 mm	14 ft 11.1 in
6	Height - Retracted with Standard 5m Boom Extension (16.4 ft)	4285 mm	14 ft	4460 mm	14 ft 7.6 in	4480 mm	14 ft 8.4 in
	Height - Extended with Standard 5m Boom Extension (16.4 ft)	5165 mm	16 ft 11.3 in	5360 mm	17 ft 7.0 in	5600 mm	18 ft 4.5 in
7	Height - Retracted with Standard 6m Boom Extension (19 ft 8.2 in)			5430 mm	17 ft 9.8 in	5130 mm	16 ft 9.1 in
	Height - Extended with Standard 6m Boom Extension (19 ft 8.2 in)			6410 mm	21 ft 0.4 in	6300 mm	20 ft 8.0 in
	Height - Ground to HIAB Crane Knuckle (Packed Up - MED360 only)	N/A		N/A		2195 mm	7 ft 2.4 in
Weights		MED150		MED210		MED360	
	Machine Total Mass*	6000 kg	13227.7 lb	9260 kg	20414.8 lb	15,655 kg	34513.3 lb
	Rack (1000 mm / 39.4 in)	89 kg	196.2 lb	103 kg	227 lb	288 kg	634.9 lb
	Rack (2000 mm / 78.7 in)	172 kg	379.2 lb	-	-	-	-
	Pin	6 kg	13.2 lb	6 kg	13.2 lb	11 kg	24.3 lb
	Rack Box	325 kg	716.5 lb	325 kg	716.5 lb	660 kg	1455 lb

*Total mass excludes vendor parts

OVER 45 YEARS IN THE MINING INDUSTRY.

Elphinstone Pty Ltd is an established Caterpillar OEM Solutions customer with over 45 years' experience in the mining industry.

Elphinstone specialises in the design, manufacture and support of quality equipment for the global underground and surface mining industries.

The Elphinstone range of products combines practical design, the latest technology and quality manufacturing to ensure reliable performance.

The current product range includes specialised underground support vehicles, mine extraction devices, extended distance off-highway haulage trucks and water tanks customised to suit Caterpillar articulated trucks.

All Elphinstone products, technical assistance, support, and access to spare parts are available through the global Cat® dealer network with additional support from the Elphinstone regional sales and support team.

MINE EXTRACTION DEVICE

For more complete information on Elphinstone products, dealer services, and industry solutions, visit www.elphinstone.com or contact your local Cat® dealer.

Material and specifications are subject to change without notice. Featured machines in photos may include additional equipment.

Elphinstone and their respective logos, as well as corporate and product identity used herein, are trademarks of Elphinstone and may not be used without permission.

© 2024 Elphinstone. All rights reserved.
Made in Australia for export.

ELPHINSTONE



HM62782-09 (12-2024)