



WR820

AGITATOR 10M³



Elphinstone Underground Support Solutions
elphinstone.com

ELPHINSTONE

UNDERGROUND RELIABILITY



**WR820 UNDERGROUND
AGITATOR 10M³**



ELPHINSTON



RELIABILITY AND PERFORMANCE IN TOUGH CONDITIONS.

Machine Safety

With safety as a priority, the WR820 is engineered with onboard machine diagnostics for rapid fault identification, increasing the availability and productivity of the machine. Fitted with a standard ROPS/FOPS open cabin, the WR820 is also available with an optional air-conditioned, enclosed cabin. Combined with the front suspension and optional air-ride seat, the ergonomic, user-friendly intuitive controls, and excellent visibility provide unrivalled comfort for the operator. The engine compression brake operates in conjunction with the automatic brake retarder, to provide superior and reliable braking capability with decreased operator input.

Maintenance and Serviceability

A swing-out radiator grill and hinged engine bonnet cover provide safe access for maintenance. Ground level access to service points reduce risk and time spent checking the machine status.

Machine Application

The WR820 chassis is heavy-duty multipurpose platform designed for various underground mining applications. Machine application includes bulk transport of concrete to back fill voids, continuous pours and construction. Excellent top speed at full capacity improves the cycle time and allows the machine to travel at the same speed as the production fleet resulting in increased production. The Caterpillar powertrain provides haulage speeds on grade equivalent to production equipment resulting in maximum productivity across the mining fleet. The bowl has a maximum capacity of 10m³ and allows mixing of wet or dry product with variable speed control.

Contents

Structures, Work Tools and Attachments	4
Operator Environment	6
Safety Features	7
Engine	8
Powertrain	9
Product Features	10
Customer Support	12
Sustainability	12
Maintenance and Serviceability	13
Technical Specifications	14
Machine Dimensions	15
Standard and Optional Equipment	16
Your Notes	18



DELIVERING POWER AND CONTROL AT FULL CAPACITY.

Machine application

- » Bulk transport of concrete to back fill voids, continuous pours and construction.
- » Transport of shotcrete to a shotcrete machine in a new development.
- » Excellent top speed at full capacity improves the cycle time and allows the machine to travel at the same speed as the production fleet resulting in increased production.

Wet or dry product loading

The 10m³ (13yd³) capacity agitator bowl can handle wet or dry product due to the machines ability to program mix and transit speeds which results in greater mixing versatility.

Water tank (optional)

Optional stainless steel water tank. On-board water storage to enable alterations to the batch or for wash down purposes. Setup includes 15m (50ft) retractable hose reel rear mounted, hydraulic water pump and external water connection.

Chemical agent tank (optional)

Optional stainless steel chemical dosing tank equipped with transfer pump. On-board chemical tanks to enable addition of agent in-situ at the work site.

Load sensing hydraulics

A load sensing variable displacement pump and pressure compensating system continually monitor hydraulic power requirements, then provides power based on demand.

Dual loading access available

Loading of the agitator bowl can be achieved vertically via the chute or horizontally via conveyor (optional).

Agitator control panel

Located on the rear right hand side of the machine, the agitator control panel features a tethered pendant control, push-button emergency stop and bowl slump meter. A fire suppression actuator is available as an option.

Mixer

- » Electro/Hydraulically controlled for mixing and unloading.
- » Manual bowl controls at ground level.
- » Quick disconnect hydraulic fittings on bowl motor for emergency discharge with external power pack.
- » Slump meter.
- » Emergency stop switch at ground level on both sides of the machine or at the top of the access platform - if fitted.

Optional features include:

- » High mounted chute camera.
- » Chute extensions.
- » Ground level bowl guards.
- » High volume, low pressure water pump and hose reel.
- » Low volume high pressure water pump and hose reel for machine washdown.
- » Chemical agent tank.



STRENGTH AND SUPERIOR BRAKING PERFORMANCE.

Heavy duty front frame

The robust, heavy duty, purpose design again utilises high tensile steel to reinforce the frame in high stress areas. With an average plate thickness of 20mm (0.8in), the frame includes belly guard access and front suspension A-frame and cylinder mounting points.

Front axle mounting and suspension

The WR820 is fitted with front suspension as standard to provide optimal operator comfort. The setup includes a robust A-frame design fitted with Caterpillar nitrogen charged suspension cylinders, providing controlled axle oscillation and vertical dampening.

Rear frame strength

The box section structure of the rear frame uses high tensile steel with an average thickness of 12mm (0.47in) in high stress areas of the frame. The increased width of the frame allows for lower positioning of the agitator bowl reducing the overall height and centre of gravity.

Bonnet and covers

The engine and radiator are easily accessible at ground level and via the service platform. Both are protected by a hinged bonnet and covers, bolt-on radiator cover and a swing-out grill.

Agitator bowl

The 10m³ agitator bowl is constructed from wear resistant plate with integrated empty bowl lifting points at the front and rear. Bowl inspection hatches are positioned on the left and right hand side of the bowl and easily accessible at ground level.

Agitator bowl drive motor and gearbox

The WR820 agitator bowl features a transmission commonly used world wide in other cement mixing applications and has proven to be reliable and easily serviced.

Major advantages of the transmission include:

- » Low-speed radial piston hydraulic motor.
- » Variable speed output ranging from 0-19rpm.
- » Up to 10 dB noise reduction: environmental friendly.
- » Increased efficiency: up to 0.5L (0.13gal) fuel saving per operating hour.
- » Tougher: improved robustness, increased lifetime, and doubled main bearing lifetime.
- » Life time oil filling: easier maintenance and cost savings.
- » Vibration isolation: absorption via elastomer unit results in improved driving comfort.
- » Quick connect fittings on bowl motor for easy change over to auxiliary hydraulic power supply.



COMFORTABLE AND EASY TO OPERATE.

Two cabin configurations available

Fitted with a standard open cabin, the WR820 is also available with an optional air-conditioned, enclosed cabin (pictured above). The modular cabin is resiliently mounted on the truck chassis, reducing vibration for greater comfort and a quieter ride. The enclosed cabin features ergonomics for operator comfort, user-friendly intuitive controls, and excellent visibility.

The cabin includes the following features:

- » ROPS/FOPS certified design.
- » Mechanical suspension seat standard.
- » Enclosed operator station available as an option with air conditioning and cabin pressurisation.
- » Seatbelt, 2-point retractable lap with optional occupancy indicator.
- » Emergency stop inside the cabin.

Engine protection system

An engine protection system is fitted that will shut down the engine if low oil pressure, low coolant level, high engine temperature or low engine temperature conditions are experienced.

Cab mounting

The modular ROPS/FOPS cabin is resiliently mounted on the truck chassis, reducing vibration for greater comfort and a quieter ride.

Monitoring controls

Conveniently located and easy-to see gauges and displays make monitoring machine systems as simple as possible. The gauges provide a constant display of vital machine functions, including engine coolant temperature, transmission oil temperature, engine oil pressure, engine speed, vehicle speed and fuel level.

Machine health monitoring system

The monitoring system and alarm strategy provides a 3-tier warning and shutdown functionality alerting the operator of any abnormalities and automatically limits the machine's functions.

Steering column

The steering column can be adjusted to an ergonomic position for maximum operator comfort by tilting or extending the column.



SAFETY FEATURES



OPERATOR SAFETY IS OUR PRIORITY.

Machine isolation

All engine and machine isolation functions are conveniently located on one panel accessible from ground level. Switches have been designed to incorporate the requirement for the site tag in/out machine isolation process.

- » Battery isolation switch.
- » Starter isolation switch.
- » Jump start receptacle.
- » Fire system activation (optional).

Cabin protective structure

The operator cabin has an integrated Rollover Protective Structure (ROPS) certified to ISO 3471:2008 and Falling Object Protective Structure (FOPS) certified to ISO 3449:2005.

Handrails

Handrails are fitted standard in accordance with ISO 2867:2011. All handrails are painted green and designed for 3-point access to cab and machine.

Steering

Full hydraulic controlled steering via opposed cylinders at the hitch. Secondary emergency steering is also provided as standard.

Braking

Service and park brakes are spring applied wet disc enclosed brakes and work in conjunction with engine compression brake. Braking systems meet ISO 3450:2011.

Additional safety features

- » Anti-skid step surfaces.
- » Inertia reel retractable seat belt.
- » Steering frame lock.
- » Electrical wiring segregation from all hydraulic hosing.
- » Fire resistant wiring.
- » Firewall / heatshields.
- » Machine interlocks (Battery and Starter) for additional protection.
- » Integrated fire suppression systems (optional).
- » Hydraulic hosing covered with burst protection sleeves (optional).
- » Door ajar warning (Operator Presence) systems.
- » Door lighting for better step visibility.
- » Window egress cord for ease of cab window removal.
- » Rear view camera (optional).
- » Park brake interlocking.
- » Empty bowl lifting points and bowl rotation lock mechanism.
- » Wheel chocks.

Service access

Easy access to daily service points simplifies servicing and time spent on regular maintenance procedures.

Ground level access

Allows convenient servicing to tanks, filters, lubrication points and compartment drains.

Interlock

If the operator fails to apply the park brake prior to exiting the cab, the interlock system will detect the absence of operator input and apply the park brake, neutralise the steering, implements and transmission.



DELIVERS POWER, PERFORMANCE AND DURABILITY.

C11 engine

The Cat C11 Tier 3 uses Caterpillar's breakthrough ACERT™ Technology to meet exhaust emission reduction standards. It features efficient fuel delivery, air management and electronic control for high productivity and exceptional service life.

Engine design

The four-stroke engine provides efficient fuel combustion. Precise engineering and thorough testing assure durability, reliability and power. Built-in serviceability and excellent fuel economy lower operating costs.

ACERT™ technology

Caterpillar optimises engine performance while meeting EPA Tier 3 regulations. ACERT™ Technology reduces emissions during the combustion process by using advanced technology in the air and fuel systems, in conjunction with integrated electronics. The Caterpillar engine meets emission regulations at the combustion source rather than recycling exhaust gases.

ADEM A4 engine control module

The ADEM A4 module controls the fuel injector solenoids to monitor fuel injection. It also provides automatic altitude compensation, and will not allow the engine to start until it has oil pressure, acting as cold start protection and a form of pre-lube.

Maintenance

The machine is equipped with Caterpillar high efficiency oil filters, whose design doubles efficiency without increasing the change interval. They provide clean oil to the engine, reducing wear on all lubricated surfaces.

Engine protection system

An engine protection system is fitted that will shut down the engine if low engine oil pressure, low coolant level, or coolant over temperature conditions are experienced.

Commonality

The Caterpillar C11 engine is found in several Caterpillar products and applications such as Medium Wheel Loaders, Excavators, Motor Graders, Marine and Industrial services. This means the WR820 shares component commonality across many applications, providing the highest level of reliability and durability, as well as superior parts availability worldwide through the Caterpillar Dealer Network.

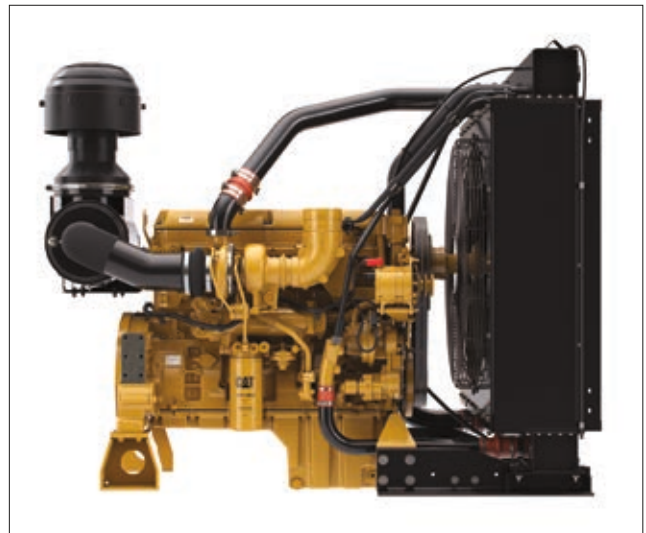



PERFORMANCE AND RELIABILITY IN TOUGH CONDITIONS.

Caterpillar four-speed transmission

The field proven Cat power shift countershaft transmission easily matches engine power to the load size and ground conditions.

Torque converter

The large, heavy-duty torque converter maximizes the productivity of the entire drive train. The torque converter is matched to the Cat C11 engine for excellent rimpull and performance.

Lock-up clutch

The integral lock-up clutch allows the machine to operate in converter drive for greater rimpull, or direct drive for high efficiency hauling and faster travel speeds. Direct drive capability allows up to 15% higher travel speeds when the lock-up clutch is engaged.

Auto lock-up

The lock-up clutch automatically engages according to ground speed and engine speed conditions. This feature is handled electronically and allows for increased travel speeds in the same gear.

Reduced shifting

The multiplication capability of the torque converter reduces the need for the operator to continually shift the transmission. This reduces operator effort and improves machine productivity.

All wheel drive (AWD)

All-wheel drive increases traction of the machine improving performance, handling and maneuverability. Delivering drive to all 4 wheel provides excellent power distribution and transfer of drive to the ground, reducing tire slippage and increasing machine capabilities in tough and challenging terrain.

Front and rear axles

The front axle is suspended on an A-frame with a nitrogen charged suspension system rigid mounted design with front suspension available as an option. The rear axle is rigidly mounted to the rear frame.

Tyres

Tyres are an integral part in a machines ability to carry it's load at higher speeds. Fitted with the larger 18:00R25 radial tyres ensures the WR820 stays within the tires TKPH limits. This allows the machine to carry larger loads at faster speeds than conventional utility equipment.

Service brakes

Spring applied hydraulically released brake system. Brake components are oil immersed inside the axles, protecting them from contamination. Modulated braking provides smooth deceleration for precision stopping and operator control.

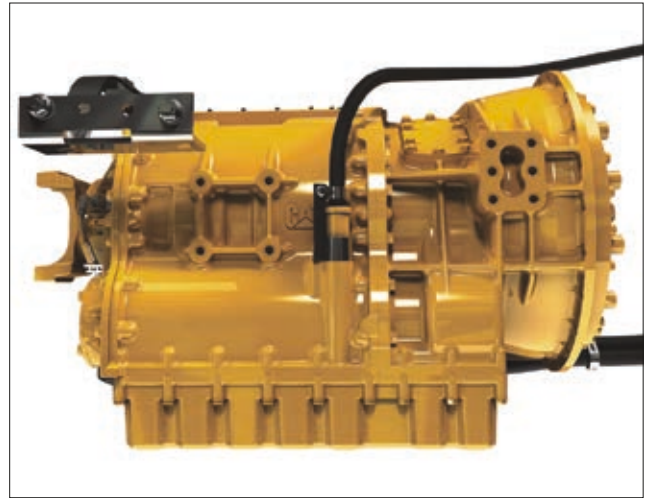

Parking brake

The parking brake is a spring applied oil released "fail to safe" enclosed wet disc on all 4-wheel ends.

Brake design

With large discs and plates for reliable, adjustment free operation and performance. Oil cooled disc brakes are completely enclosed to prevent contamination and reduce maintenance.

Engine compression brake

The engine compression brake has 3 user selectable levels of operation for improved controllability in all conditions.

Emergency braking

When the WR820 safety system detects loss of critical drive pressure or brake pressure the operator will receive a warning and then the parking brake system will safely apply.

Load sensing

A load sensing variable displacement pump and pressure compensating system continually monitor hydraulic power requirements, then provides power based on demand. This improves fuel economy and reduces emissions.

Other features include suction circuits, pump case-drain and steering return, filtered fan/brake pressure circuit, and closed loop hydraulic system.



FEATURE OVERVIEW

FOR IMPROVED RIDE CAPABILITY, SPEED AND PRODUCTIVITY UNDERGROUND.

● Standard ● Optional ● Safety

SWING OUT RADIATOR GRILL

Provides easy access to facilitate cleaning and maintenance on cooling system

CLIMATE CONTROLLED ENCLOSED CABIN

SURFACE FEEDBACK

Pitch and roll data on ground conditions

2x LED BEACONS

Front and rear of cab

HEATED MIRRORS

EMERGENCY STOP

With LED visual feedback

CENTRE MACHINE RETRIEVAL POINT

Painted red

MACHINE TIE DOWN POINTS

Painted red

CATERPILLAR POWERTRAIN

Proven Cat C11 Tier engine with CX31 Transmission

ENGINE COMPRESSION BRAKE

Operates in conjunction with the automatic brake retarder providing superior and reliable braking

ROTATING BEACON

Multiple colours available

FIRE EXTINGUISHER

STEP TREADS

Painted in high visibility green

AGITATOR BOWL AND VARIABLE SPEED CONTROL

Provides a set range of variable control for drum speed from cabin and/or the RHS rear of the machine via tethered control

AGITATOR HYDRAULIC PUMP

Manual override for bowl discharge

INDEPENDENT BRAKE COOLING

Tank on RHS mudguard, and brakes in wheel ends

FIXED HANDRAILS

Standard on all machines painted green

FOLDING HANDRAILS

Painted green (pictured)

3-PIECE WHEEL RIMS

ALL WHEEL DRIVE

MACHINE ISOLATION

Located at ground level adjacent to operators cabin

AUTO LUBRICATION PUMP

Automatically supplies grease to all lubricating points on machine

BURST PROTECTION SHEATHING

Entire machine

HOSES AND HARNESSES BULK HEADED IN HITCH

FUEL CAP ISOLATION SYSTEM

AGITATOR HYDRAULIC MOTOR

Includes quick coupler hose connections

FRONT SUSPENSION

Suspended front axle on A-Frame with nitrogen charged suspension system

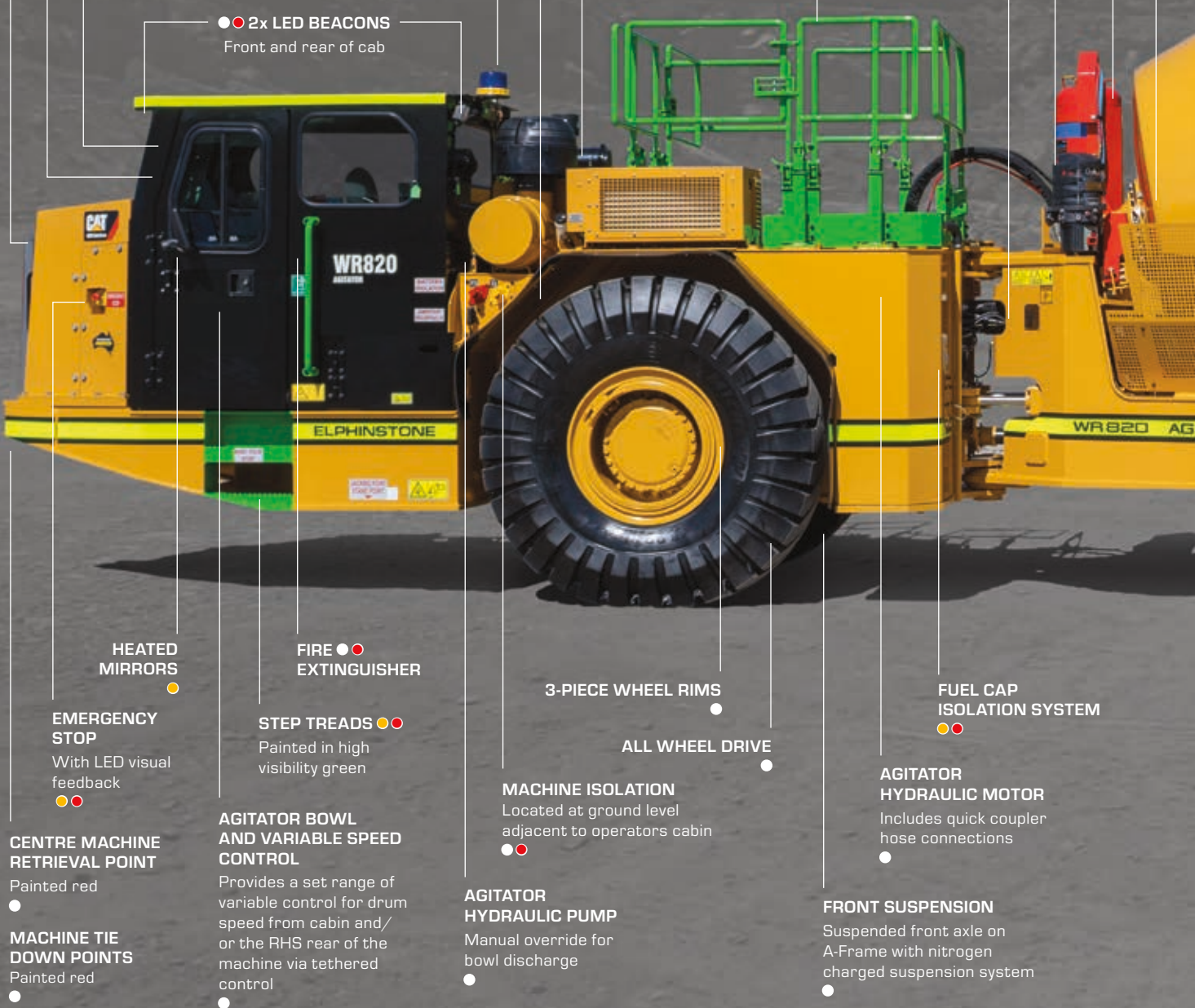



LARGER 10M³ AGITATOR BOWL
Includes two hatches 180 degrees apart and lifting points on front and rear of bowl

DIGITAL SLUMP METER
Reading in cabin and on manual gauge at the rear of the machine

FIRE SUPPRESSION SYSTEM
Dry powder or aqueous film forming foam (AFFF)

FIRE EXTINGUISHERS
1x RHS rear mudguard, 1x LHS rear mudguard

REAR ACCESS STEPS & PLATFORM
3 points of contact with hand rails and self-closing gate (Not shown)

BOWL MOTOR QUICK CONNECT COUPLINGS
For easy change over to auxiliary hydraulic power

EXTENDED AXLE BREATHERS
Front and rear

HEAVY DUTY BOWL STRAP **TRUNNION ROLLER GUARDS**

EXTENSION CHUTES
(Not shown)

DRIVESHAFT GUARD LOOPS

WHEEL CHOCKS
2x chocks stored on mounts on rear mudguards can be mounted either side

HIGH PERFORMANCE HEAVY-DUTY AXLES

EMERGENCY STOP
Cabin, engine bay and both sides rear

AGITATOR BOWL GUARDING
To prevent entrapment when bowl is operating

265 L CHEMICAL TANK

WHEEL NUT INDICATORS

ADDITIVE BOTTLE STORAGE COMPARTMENTS
Both sides can store 20 L containers with tie down points

REAR STABILISER CYLINDERS
Provides levelling function when parked on unsuitable ground for discharging

235 L WATER TANK WITH HOSE REEL



CUSTOMER SUPPORT

WHEN UPTIME REALLY COUNTS.

Renowned Cat dealer support

From helping you choose the right machine to financing and ongoing support, your Cat dealer provides the best in sales and service.

- » Manage your costs with preventive maintenance programs like SOSSM fluids analysis, coolant sampling and guaranteed maintenance contracts.
- » Stay productive with best-in-class parts availability.
- » Your Cat dealer can also help you boost efficiency with operator training.
- » When it's time for component replacement, your Cat dealer can help you save even more. Genuine Cat remanufactured parts carry the same warranty and reliability as new products at savings of 40 to 70 percent for powertrain and hydraulic components.

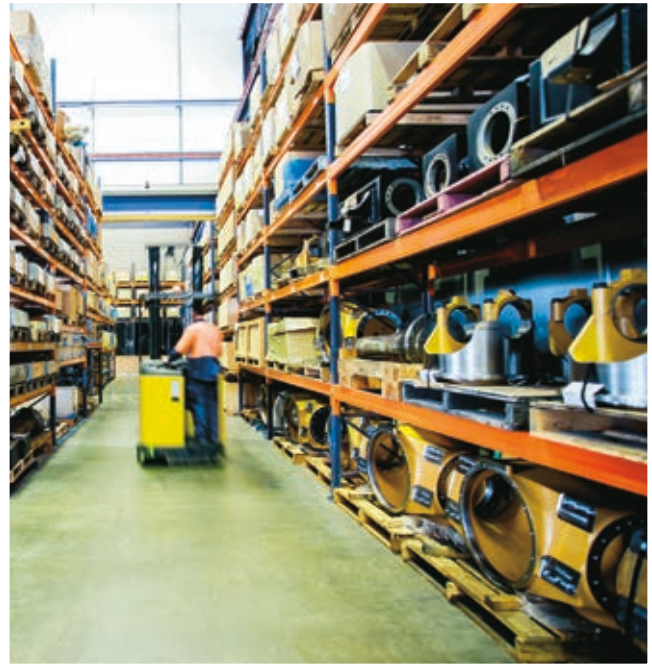

FUTURE SUSTAINABILITY

THINKING INTO THE FUTURE.

Sustainable waste and cost management

- » Integrated machine systems and technologies improve productivity for greater accuracy, lower fuel use and reduced machine wear.
- » Replaceable wear parts save maintenance time and cost, and extend major component life.
- » Ecology drains help make draining fluids more convenient and help prevent spills.
- » Major components are built to be rebuilt, eliminating waste and saving customers money by giving the machine and/or major components a second – and even third life.
- » A variety of safety features help safeguard operators and others on the job site.

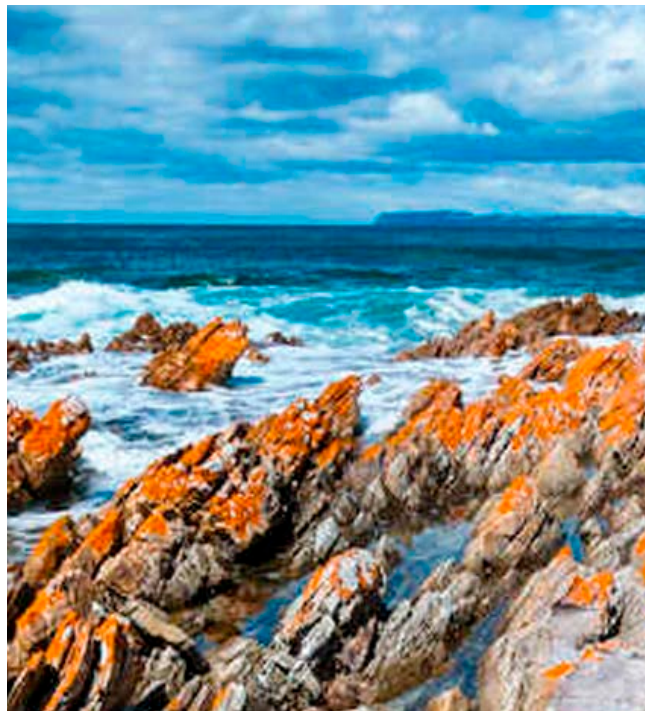



SERVICEABILITY MEANS MORE TIME FOR PRODUCTION.

Frame access

Steps and grab handles are standard on the engine end frame and cab for easy access to the service and operation areas.

Bolt-on guards.

Bolt-on belly guards offer protection to critical components, are hinged and easily removable for servicing.

Air filters

Radial seal air filters makes them easy to change, reducing air filter maintenance times. Filters and lubrication points are accessible from the ground without special tools. Remote lubrication points make daily attention to hard-to-reach joints easy.

Diagnostics

Electronic control system enables quick diagnosis of engine/transmission conditions and effective maintenance and repairs.

Pressure taps

Conveniently located for easy access to hydraulic system pressure measurements.

Spin-on oil filters

Spin-on fuel and engine oil filters shorten downtime.

Ecology drains

The hydraulic tank features ecology drains to make regular maintenance easier, and protect the environment from accidental oil spills.

Centralised service centre

Includes battery isolation and fluid sampling points as standard, with fast fill and evacuation points available as an option.

Electrical system

The 24V electrical system delivers a reliable electrical capacity for engine starting and additional lighting. Wiring circuits are colour coded and numbered for easy diagnosis and repair. All circuits are protected by circuit breakers. All harness connections have sealed electrical connectors to prevent moisture and dirt ingress. Harnesses are covered with fire resistant material for additional protection. All battery cables are double insulated for extra protection against rubbing.

On-board diagnostic systems

The monitoring system continuously checks all critical machine functions and components, and helps locate faults quickly for faster repair.



TECHNICAL SPECIFICATIONS

Engine

Engine Model	Cat C11 ACERT Tier 3	
Gross Power SAE J1995	242 kW	325 hp
Net Power ISO9249	239 kW	321 hp
Net Power SAE J1349	237 kW	317 hp
Displacement	11.15 L	680 in ³
Bore	130 mm	5.1 in
Stroke	140 mm	5.5 in
Number of Cylinders	6	
Max Torque @ Rated Speed	1430 Nm @ 1300rpm	
Derating Altitude 3048 m 9843 ft	3048 mn	9843 ft

- These ratings apply at 1,800 rpm when tested under the specified standard conditions
- Net power advertised is the power available at the flywheel when the engine is equipped with fan, air cleaner, muffler and alternator. No derating required up to 3,000 m (9,843 ft) altitude
- Based on standard air conditions of 25°C (77° F) and 99 kPa (29.32 in Hg) dry barometer. Used 35 API gravity fuel having an LHV of 42,780 kJ/kg (18,390 BTU/lb) when used at 30° C (86° F) [ref. A fuel density of 838.9 g/L (7.001 lb/gal)]

Electrical

Alternator	150 amp
Electrical System	24 V
Battery - Quantity	2
Battery - Volts	12 V
Battery - Capacity	1400CCA
Starting System	Direct Electric

Powertrain

Travel Speed - Fwd. 1st	5.5 km/h	3.4 mph
Travel Speed - Fwd. 2nd	10.4 km/h	6.5 mph
Travel Speed - Fwd. 3rd	15.9 km/h	9.9 mph
Travel Speed - Fwd. 4th	24.3km/h	15.1 mph
Travel Speed - Rev. 1st	6.1 km/h	3.8 mph
Transmission	4 fwd / 1 rev powershift	
Transmission Cooler Type	Tube and Bund	
Steering, Frame Articulation	+/- 42.5°	
Brakes - Service Type	Multiple WET disc enclosed Spring applied wheel ends	
Brakes - Parking Type	Multiple WET disc enclosed Spring applied wheel ends	
Tyres	18.00 R25	

Hydraulic System

Circuit Type	Closed centre variable flow	
Pump Type	Axial piston	
Pump Output	174 L/min	46 gal/min
Relief Valve Setting	21,000 kPa	3,045 psi
Steering Valve	Direct link, non follow	
Steering Cylinder - Bore	114.3 mm	4.5 in
Steering Cylinder - Stroke	437.5 mm	17.22 in
Steering Cylinder - Rod Diameter	50.8 mm	2 in

Service Refill

Fuel Tank	361 L	94 gal
Cooling System	67 L	18 gal
Differential, Final Drive - F	55 L	14.5 gal
Differential, Final Drive - R	55 L	14.5 gal
Engine Oil	41 L	11 gal
Transmission, Torque Converter	36 L	9.5 gal
Hydraulic Tank	151 L	49 gal
Brake Cooling Tank	67 L	18 gal

Weights

Gross Vehicle Weight (GVM)	50,095 kg	110,440 lb
Tare Weight	26,020 kg	57,364 lb

*Tare weight includes one operator and a full tank of fuel.

Speed on Grade

Grade	Vehicle Speed (km/h)				
	1st Fwd	2nd Fwd	3rd Fwd	4th Fwd	1st Rev
1:7 (14%) Empty (26,020 kg)	5.5	10.4	15.9	17.4	6.1
1:7 (14%) GVM (50,095 kg)	5.5	9.9	-	-	6.1

*Note: 2% rolling resistance

Agitator

Drum Volume						
Mixing / Carrying Capacity					10 m ³	
100% Drum Volume					17.29 m ³	
Bowl Capacities						
Material SG (kg/m ³)	2000	2100	2200	2300	2400	2500
Max. Fill Capacity (m ³)	10 m ³	10 m ³	10 m ³	10 m ³	10 m ³	9.6 m ³

Standards

ROPS/FOPS	ISO 3471:2008 / ISO 3449:2005
Steering	ISO 5010:2007
Braking	ISO 3450-2011/CSA-M424.3-M90



MACHINE DIMENSIONS

Turning Radius

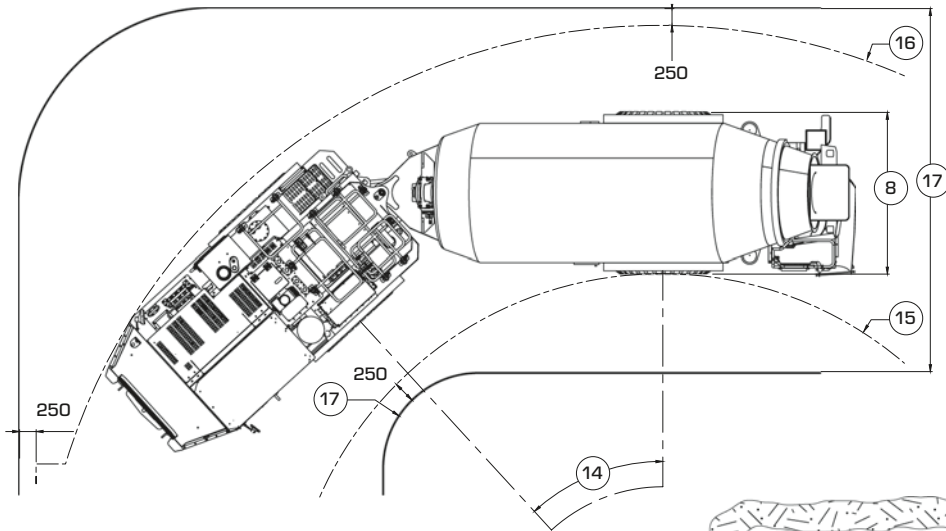

Side View and Drive Size

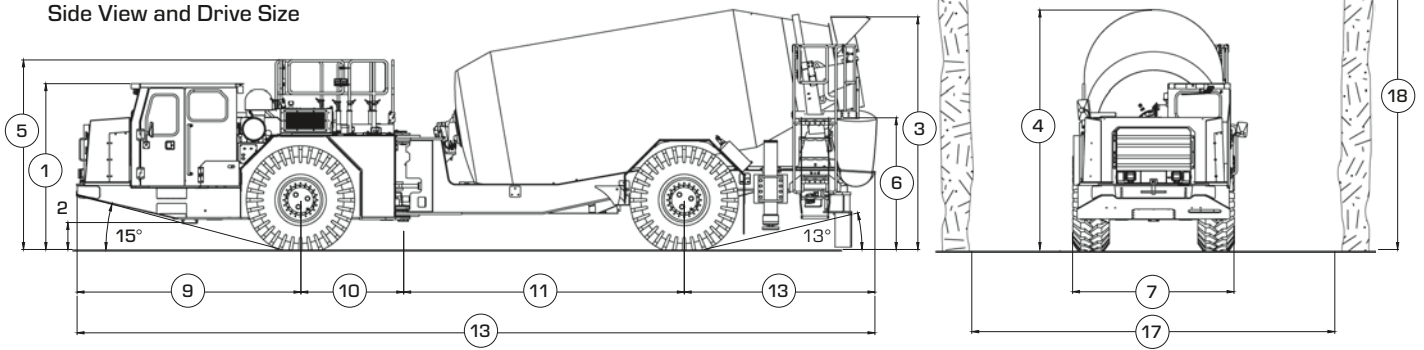

Dimensions

1	Height - Top of Cab	2515 mm	8 ft 3 in
2	Height - Ground Clearance	410 mm	1 ft 2.1 in
3	Height - Top of Feed Chute	3520 mm	11 ft 6.5 in
4	Height - Top of Agitator	3630 mm	11 ft 10.9 in
5	Height - Top of Rails	2870 mm	8 ft 6.9 in
6	Height - Ladder Platform (Optional)	2000 mm	6 ft 6.7 in
7	Width - Machine Front Frame	2445 mm	8 ft 0.3 in
8	Width - Machine Rear Frame	2445 mm	8 ft 0.3 in
9	Length - Front Axle to Bumper	3390 mm	11 ft 1.5 in
10	Length - Front Axle to Hitch	1560 mm	5 ft 1.4 in
11	Length - Hitch to Rear Axle	4250 mm	13 ft 11.3 in
12	Length - Rear Axle to Chute	2890 mm	9 ft 5.8 in
13	Length - Overall	12090 mm	39 ft 7.9 in
14	Articulation	42.5°	

Drive Size

15	Radius - Inside Clearance	5725 mm	18 ft 9.4 in
16	Radius - Outside Clearance	9495 mm	31 ft 1.8 in
17	Width - Drive Clearance	5500 mm	18 ft 0.5 in
18	Typical Minimum Height Portal	5000 mm	16 ft 4.8 in



STANDARD AND OPTIONAL EQUIPMENT

● Standard ● Optional ● Safety

Powertrain		Operator Environment	
4WD Transfer Box	●	Mirrors, Rear View	●
A-Frame Suspension Cradle with Nitrogen Filled Cylinders	●	Rear Window Guard	●
Air Cleaner, 2-Stage with Rain Cap	●	Seat Cover	●
Axle Breathers, Remote Mounted	●	Seat, Suspension - Active Air	●
Brakes - Engine Compression	●	Seat, Suspension - Air	●
Brakes - Parking, Four Wheel Spring Applied, Pressure Release, Enclosed Disc	●	Seat, Suspension - Mechanical	●
Brakes - Service, Four Wheel Spring Applied Pressure Release, Enclosed Disc	●	Seatbelt, 2-point, Retractable Lap	●●
Coolant, Arctic Extended Life -52°C Protection	●	Seatbelt, 2-point, Retractable Lap, Occupancy Indicator	●●
Coolant, Extended Life -37°C Protection	●	Steering Wheel, Tilt and Telescoping	●
Cooling Package, Radiator And Aftercooler	●	Storage Compartment	●●
Driveline Slip-Joint, Lubricated for Life	●	Instrumentation, Gauges	
Engine, Exhaust Manifold, Shielded and Insulated	●●	Brake, Accumulator Pressure	●
Engine, Cat C11, ACERT Technology, ATAAC	●	Brake, Parking, Pressure	●
Engine, Exhaust, Diesel Particulate Filter with Back Pressure Monitoring	●	Brake, Service, Pressure	●
Engine, Overspeed Inhibitor	●	Engine, Coolant Temperature	●
Engine, Shutdown System to Idle/Stop	●	Engine, Oil Pressure	●
Fan, Hydraulic, Sucker, Temperature Controlled	●	Fuel Level	●
Filters, Fuel (Primary/Secondary)/Engine Air, Hydraulic Oil, Pump Case Drain, Brake Cooling Oil, Implement	●	Speedometer	●
Final Drives, Inboard Planetary	●	Steering System Pressure	●
Fire Resistant Sheathing on Fuel Lines, External	●	Tachometer	●
Front Axle, Fixed, Mounted to Suspension Cradle	●	Transmission, Oil Temperature	●
Fuel Tank, High Capacity	●	Instrumentation, Warning Indicators	
Fuel Transfer Pump (Mechanical)	●	Brake, Accumulator Oil Pressure	●
Lock-Up Torque Converter	●	Brake, Cooling Filter Back Pressure	●
Low Transmission Oil Pressure Monitoring	●	Brake, Cooling Oil Level	●
Manual Fuel Shutoff Valve at the Tank	●	Brake, Cooling Oil Temperature	●
Muffler/Catalytic Converter	●	Brake, Fault	●
Stainless Steel Braided Fuel Lines, External	●	Brake, Parking, Application	●
Steering, Rotary Metering Pump	●	Charging System	●
Transmission, Power-Shift (4F/1R) With Auto-Shift Function	●	Door Open	●
Universal Joints with Lube Points	●	Emergency Stop, Activation	●
Fast-fill systems		Engine, Coolant Level	●
Coolant, Engine Oil, Hydraulic Oil, Transmission Oil, Brake Cooling Oil	●	Engine, Coolant Temperature	●
Fuel	●	Engine, Fault	●
Fuel with Machine Isolation	●	Engine, Oil Pressure	●
Operator Environment		Hydraulic, Oil Level	●
Brake Retarder Control, Automatic	●●	Hydraulic, Oil Temperature	●
Brake Retarder Control, Manual	●	Lights, Work - Bowl	●
Brakes, Park, Onboard - Push to Engage	●●	Lockup Clutch	●
Brakes, Park, Onboard - Pull to Engage	●●	Primary Steering Pressure	●
Cabin, Open, ROPS/FOPS	●●	Retarder On	●
Cabin, Enclosed, ROPS/FOPS, Climate Controlled Air Conditioning System, Window Sliding Operator, Windshield Wiper Washer, Window Emergency Egress Seals	●●	Seat Belt	●
Camera, Agitator Discharge Chute	●●	Secondary Steering Pressure	●
Camera, Off-side	●●	Stabilizers Down	●
Camera/Monitor, Reversing	●●	Torque Converter, Oil Temperature	●
Door Pocket	●●	Transmission Fault	●
Fire Extinguisher, 4.5 kg, Hand Held Dry Chemical Powder 4A:60B:E LH Side	●●	Transmission Filter Bypass	●
Heated Mirrors, Rear View	●	Instrumentation, Digital Data	
Holder, Water Bottle	●●	Computerised Diagnostics and Monitoring	●
Light, Dome	●	Gear and Direction	●
Light, Entry	●●	Odometer	●
		Service Hour Meter	●
		Electrical	
		Accessory Power Port (12 V)	●
		Alarm, Back-up	●●
		Alternator, 100 amp	●



STANDARD AND OPTIONAL EQUIPMENT

● Standard ● Optional ● Safety

Electrical

Alternator, High Output, 150 amp (Part of Enclosed operator station (FOPS/ROPS))	●
Auxiliary Start Receptacle	●
Batteries, Maintenance Free (2x 1400 CCA)	●
Battery Isolation, Lockable Disconnect Switch (2 Pole)	●●
Battery Isolation, (4 Pole)	●●
Beacon, Flashing, LED, Front/Rear of Cab (Amber)	●●
Beacon, Flashing, LED, Front/Rear of Cab (Blue)	●●
Beacon, Flashing, LED, Rear (Amber)	●●
Beacon, Flashing, LED, Rear (Blue)	●●
Beacon, Rotating, Cab, Mounted (Various Colours Available)	●●
Diagnostic Connector	●
Digital Inclinometer Display, Dashboard	●●
Electrical Connectors, Sealed	●
Electronic Monitoring System	●
Emergency Stop - Cabin	●●
Emergency Stop - Ground Level, RH Side, Engine Bay	●●
Emergency Stop - Ground Level, LH Side Front	●●
Emergency Stop - Ground Level, Rear Bowl Control Panel	●●
Emergency Stop - Ground Level, Rear Cab Side with or without Platform	●●
Horn, Warning	●●
Lights, Stop/Tail/Turn	●
Lights, Brake and Tail	●
Lights, Headlights with Dip Switch	●
Lights, Bowl, Rear - Sides of Bowl	●
Lights, Work, Rear - Cab Mounted	●
Lights, Work, Rear - Chute and Control Panel	●
Lights, Work, Rear - Offside/Stair Access	●
Lights, Work, Rear - Top of Bowl Support	●
Lights, Reversing	●
Operator Presence	●●
Starter Isolator, Lockable	●●
Starter Isolator, (4 Pole)	●●
Starter, Electric, Heavy Duty	●
Starting and Charging System (24 V)	●
USB Charger Outlet (5 V)	●

Hydraulics

Bowl Motor with Quick-Connect Lines	●
Brakes, Cooling Filters	●
Brakes, Cooling Oil Coolers	●
Brakes, Separate Cooling Tank	●
Burst Protection, Hoses	●●
Closed Centre, Load Sensing System	●
Hydraulic Oil Cooler	●
Line Filter, Full Flow Return	●

Agitator

Additive Bottle Mount 1x 20 L	●
Additive Bottle Mount 2x 20 L	●
Additive Pump, Manual	●
Bowl Fill - Rear Load to Suit Conveyor	●
Bowl Fill - Top Chute Load to Suit Hopper	●
Bowl, Access Platform/Ladder	●
Bowl, Auxiliary Motor Discharge Hose Kit, Emergency	●
Bowl, Guards (Hitch to Bowl Support)	●●
Bowl, Spray Nozzle, Fixed	●

Agitator

Bowl, Trunion Guards	●
Chute Extension	●
Chute Extension, Placement	●
Rear Stabilisers	●
Tank, Chemical Dosing with Pneumatic Pump, 265 L	●
Tank, Water, 235 L	●
Water Pump, High Pressure, Hose, Reel	●
Water Pump, High Volume, Hose, Reel	●

Other

Anti-Corrosion Protection Spray	●
Articulation Lock Link	●●
Centralised Service Centre (Grouped Filters, Transmission Fill and Engine Fill)	●
Ecology Drains (Hydraulic Tank)	●
Engine, Enclosures, Hinged	●
Film, Gp Reflective, Fluorescent Orange	●●
Film, Gp Reflective, Fluorescent Yellow	●●
Fire Extinguisher, 9 kg, Hand Held Dry Chemical Powder 6A:80B:e LH and RH Side	●●
Fire Suppression System, Ansul A101 Dry Chemical Powder, Engine Shutdown	●●
Fire Suppression System, Sandvik Aqueous-Film Forming Foam, Engine Shutdown	●●
Firewall	●●
Grease Lubrication System, Automatic	●
Grease Lubrication System, Centralised, Manual	●
Guards, Pivoting, Under Engine And Transmission	●
Handrails, Fixed for Top Covers	●
Handrails, Folding for Top Covers	●
Handrails, Painted Contrasting High-visibility Green	●●
Ladder, Folding, Engine Access	●●
Lift, Tie Down and Retrieval Points (Front and Rear)	●
Mudguards	●
Oil Sampling Ports, SOS	●
Radiator Ap, Manual, Anti-scald Pressure Release	●●
Rim Identification	●
Rim, Spare (18.00R25)	●
Steering Lockout, Park Brake Engaged	●●
Steering, Secondary	●●
Tank, Coolant Make Up	●
Tooling - Empty Bowl Lifting	●●
Tooling - Engine Timing	●
Tyre and Rim, Spare (18.00R25)	●
Tyres and Tubeless Rims (18.00R25)	●
Wheel Chocks 2x (Checkers, MC3010)	●●
Wheel Chocks 2x (Checkers, UC1210)	●●
Wheel Nut Retention Indicators	●●

OVER 45 YEARS IN THE MINING INDUSTRY.

Elphinstone Pty Ltd is an established Caterpillar Original Equipment Manufacturer with over 45 years' experience in the mining industry. Elphinstone specialises in the design, manufacture and support of quality equipment for the global underground and surface mining industries.

The Elphinstone range of Underground Mining Support Vehicles combines practical design, the latest technology and quality manufacturing to ensure reliable performance.

The current product range includes specialised underground support vehicles, mine extraction devices, extended distance off-highway haulage trucks and water tanks customised to suit Caterpillar articulated trucks.

As an established Caterpillar Original Equipment Manufacturer, all Elphinstone products are sold and supported via the global Cat® dealer network.

WR820 AGITATOR 10M³

For more complete information on Elphinstone products, dealer services, and industry solutions, visit www.elphinstone.com or contact your local Cat dealer.

Material and specifications are subject to change without notice. Featured machines in photos may include additional equipment.

Elphinstone and their respective logos, as well as corporate and product identity used herein, are trademarks of Elphinstone and may not be used without permission.

© 2024 Elphinstone. All rights reserved.
Made in Australia for export.

ELPHINSTONE



HM06624-03 (10-2024)