



WR820

AGITATOR 8M³



Elphinstone Underground Support Solutions
elphinstone.com

ELPHINSTONE

UNDERGROUND RELIABILITY



TECHNICAL SPECIFICATIONS

Engine

Engine Model	Cat C11 ACERT Tier 3	
Gross Power SAE J1995	242 kW	325 hp
Net Power ISO9249	239 kW	321 hp
Net Power SAE J1349	237 kW	317 hp
Displacement	11.15 L	680 in ³
Bore	130 mm	5.1 in
Stroke	140 mm	5.5 in
Number of Cylinders	6	
Max Torque @ Rated Speed	1430 Nm @ 1300rpm	
Derating Altitude 3048 m 9843 ft	3048 mn	9843 ft

- These ratings apply at 1,800 rpm when tested under the specified standard conditions
- Net power advertised is the power available at the flywheel when the engine is equipped with fan, air cleaner, muffler and alternator. No derating required up to 3,000 m (9,843 ft) altitude
- Based on standard air conditions of 25° C (77° F) and 99 kPa (29.32 in Hg) dry barometer. Used 35 API gravity fuel having an LHV of 42,780 kJ/kg (18,390 BTU/lb) when used at 30° C (86° F) [ref. A fuel density of 838.9 g/L (7.001 lb/gal)]

Electrical

Alternator	150 amp
Electrical System	24 V
Battery - Quantity	2
Battery - Volts	12 V
Battery - Capacity	1400CCA
Starting System	Direct Electric

Powertrain

Travel Speed - Fwd. 1st	5.5 km/h	3.4 mph
Travel Speed - Fwd. 2nd	10.4 km/h	6.5 mph
Travel Speed - Fwd. 3rd	15.8 km/h	9.8 mph
Travel Speed - Fwd. 4th	24.2km/h	15.0 mph
Travel Speed - Rev. 1st	6.1 km/h	3.8 mph
Transmission	4 fwd / 1 rev powershift	
Transmission Cooler Type	Tube and Bund	
Steering, Frame Articulation	+/- 42.5°	
Brakes - Service Type	Multiple WET disc enclosed Spring applied wheel ends	
Brakes - Parking Type	Multiple WET disc enclosed Spring applied wheel ends	
Tyres	18.00 R25	

Hydraulic System

Circuit Type	Closed centre variable flow	
Pump Type	Axial piston	
Pump Output	174 L/min	46 gal/min
Relief Valve Setting	21,000 kPa	3,045 psi
Steering Valve	Direct link, non follow	
Steering Cylinder - Bore	101.6 mm	4 in
Steering Cylinder - Stroke	437.5 mm	17.22 in
Steering Cylinder - Rod Diameter	50.8 mm	2 in

Service Refill

Fuel Tank	361 L	94 gal
Cooling System	67 L	18 gal
Differential, Final Drive - F	55 L	14.5 gal
Differential, Final Drive - R	55 L	14.5 gal
Engine Oil	41 L	11 gal
Transmission, Torque Converter	36 L	9.5 gal
Hydraulic Tank	151 L	49 gal
Brake Cooling Tank	67 L	18 gal

Weights

Gross Vehicle Weight (GVM)	42,200 kg	93,035 lb
Tare Weight	23,060 kg	50,839 lb

*Tare weight includes one operator and a full tank of fuel.

Speed on Grade

Grade	Vehicle Speed (km/h)				
	1st Fwd	2nd Fwd	3rd Fwd	4th Fwd	1st Rev
1:7 (14%) Empty (23,060 kg)	5.5	10.4	15.8	20.8	6.1
1:7 (14%) GVM (42,200 kg)	5.5	10.4	-	-	6.1

*Note: 2% rolling resistance

Agitator

Drum Volume						
Mixing / Carrying Capacity					8 m ³	
100% Drum Volume					12.4 m ³	
Bowl Capacities						
Material SG (kg/m ³)	2000	2100	2200	2300	2400	2500
Max. Fill Capacity (m ³)	8 m ³	8 m ³	8 m ³	8 m ³	8 m ³	7.6 m ³

Standards

ROPS/FOPS	ISO 3471:2008 / ISO 3449:2005
Steering	ISO 5010:2007
Braking	ISO 3450-2011/CSA-M424.3-M90



MACHINE DIMENSIONS

Turning Radius

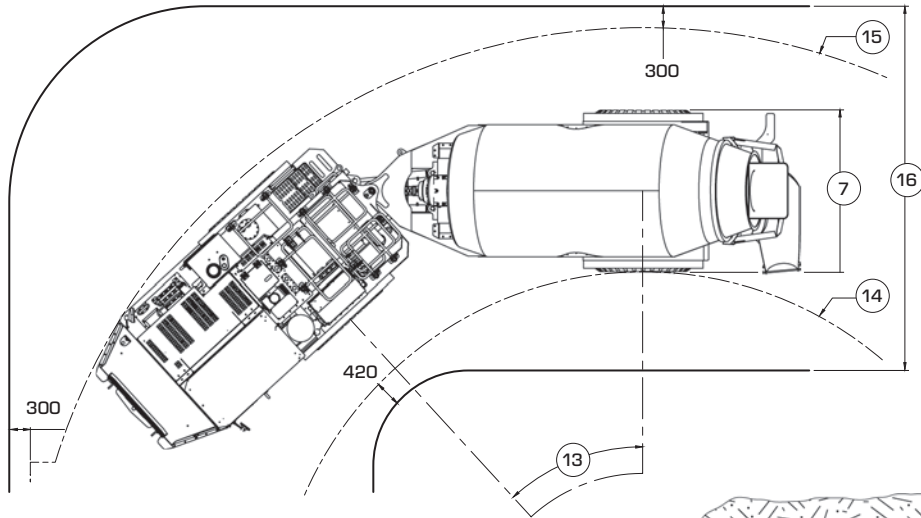

Side View and Drive Size

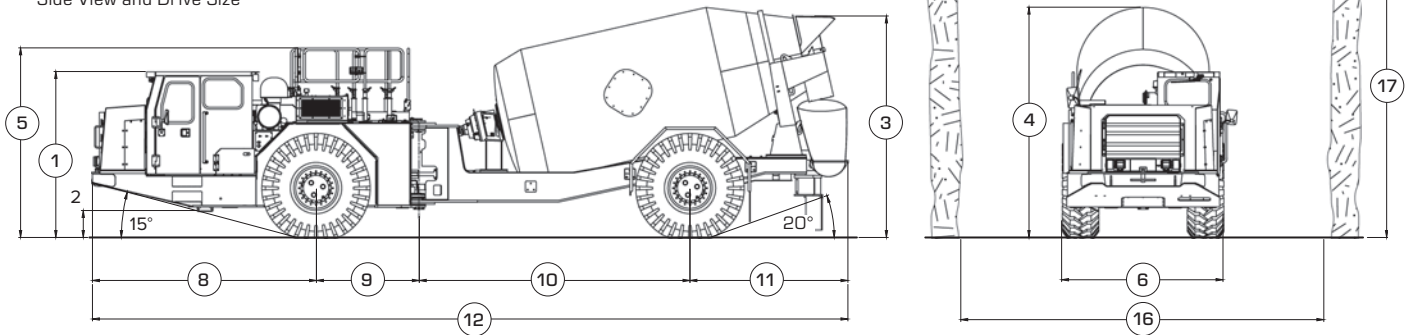

Dimensions

1	Height - Top of Cab	2515 mm	8 ft 3 in
2	Height - Ground Clearance	410 mm	1 ft 4.1 in
3	Height - Top of Feed Chute	3355 mm	11 ft 0.9 in
4	Height - Top of Agitator	3490 mm	11 ft 5.4 in
5	Height - Top of Rails	2870 mm	9 ft 4.9 in
6	Width - Machine Front Frame	2445 mm	8 ft 0.3 in
7	Width - Machine Rear Frame	2445 mm	8 ft 0.3 in
8	Length - Front Axle to Bumper	3390 mm	11 ft 1.5 in
9	Length - Front Axle to Hitch	1560 mm	5 ft 1.4 in
10	Length - Hitch to Rear Axle	4100 mm	13 ft 5.4 in
11	Length - Rear Axle to Chute	2395 mm	7 ft 10.3 in
12	Length - Overall	11445 mm	37 ft 6.6 in
13	Articulation	42.5°	

Drive Size

14	Radius - Inside Clearance	5555 mm	18 ft 2.7 in
15	Radius - Outside Clearance	9275 mm	30 ft 5.2 in
16	Width - Drive Clearance	5500 mm	18 ft 0.5 in
17	Typical Minimum Height Portal	5000 mm	16 ft 4.8 in



STANDARD AND OPTIONAL EQUIPMENT

● Standard ● Optional ● Safety

Powertrain	
4WD Transfer Box	●
Air Cleaner, 2-Stage with Rain Cap	●
Axle Breathers, Remote Mounted	●
Brakes - Engine Compression	●
Brakes - Parking, Four Wheel Spring Applied, Pressure Release, Enclosed Disc	●
Brakes - Service, Four Wheel Spring Applied Pressure Release, Enclosed Disc	●
Coolant, Arctic Extended Life -52°C Protection	●
Coolant, Extended Life -37°C Protection	●
Cooling Package, Radiator And Aftercooler	●
Driveline Slip-Joint, Lubricated for Life	●
Engine, Exhaust Manifold, Shielded and Insulated	●
Engine, Cat C11, ACERT Technology, ATAAC	●
Engine, Exhaust, Diesel Particulate Filter With Back Pressure Monitoring	●
Engine, Overspeed Inhibitor	●
Engine, Shutdown System to Idle/Stop	●
Fan, Hydraulic, Sucker, Temperature Controlled	●
Filters, Fuel (Primary/Secondary)/ Engine Air, Hydraulic Oil, Pump Case Drain, Brake Cooling Oil, Implement	●
Final Drives, Inboard Planetary	●
Fire Resistant Sheathing on Fuel Lines, External	●
Front Axle, Oscillating	●
Fuel Tank, High Capacity	●
Fuel Transfer Pump (Mechanical)	●
Lock-Up Torque Converter	●
Low Transmission Oil Pressure Monitoring	●
Manual Fuel Shutoff Valve at the Tank	●
Muffler/Catalytic Converter	●
Stainless Steel Braided Fuel Lines, External	●
Steering, Rotary Metering Pump	●
Transmission, Power-Shift (4F/ 1R) With Auto-Shift Function	●
Universal Joints with Lube Points	●
Fast-fill systems	
Coolant, Engine Oil, Hydraulic Oil, Transmission Oil, Brake Cooling Oil	●
Fuel	●
Fuel with Machine Isolation	●
Operator Environment	
Brake Retarder Control, Automatic	●
Brake Retarder Control, Manual	●
Brakes, Park, Onboard - Push to Engage	●
Brakes, Park, Onboard - Pull to Engage	●
Cabin, Open, ROPS/FOPS	●
Cabin, Enclosed, ROPS/FOPS, Climate Controlled Air Conditioning System, Window Sliding Operator, Windshield Wiper Washer, Window Emergency Egress Seals	●
Camera, Agitator Discharge Chute	●
Camera, Off-side	●
Camera/Monitor, Reversing	●
Door Pocket	●
Fire Extinguisher, 4.5 kg, Hand Held Dry Chemical Powder 4A:60B:E LH Side	●
Heated Mirrors, Rear View	●
Holder, Water Bottle	●
Light, Dome	●
Light, Entry	●
Mirrors, Rear View	●

Operator Environment	
Rear Window Guard	●
Seat Cover	●
Seat, Suspension - Active Air	●
Seat, Suspension - Air	●
Seat, Suspension - Mechanical	●
Seatbelt, 2-point, Retractable Lap	●
Seatbelt, 2-point, Retractable Lap, Occupancy Indicator	●
Steering Wheel, Tilt and Telescoping	●
Storage Compartment	●
Instrumentation, Gauges	
Brake, Accumulator Pressure	●
Brake, Parking, Pressure	●
Brake, Service, Pressure	●
Engine, Coolant Temperature	●
Engine, Oil Pressure	●
Fuel Level	●
Speedometer	●
Steering System Pressure	●
Tachometer	●
Transmission, Oil Temperature	●
Instrumentation, Warning Indicators	
Brake, Accumulator Oil Pressure	●
Brake, Cooling Filter Back Pressure	●
Brake, Cooling Oil Level	●
Brake, Cooling Oil Temperature	●
Brake, Fault	●
Brake, Parking, Application	●
Charging System	●
Door Open	●
Emergency Stop, Activation	●
Engine, Coolant Level	●
Engine, Coolant Temperature	●
Engine, Fault	●
Engine, Oil Pressure	●
Hydraulic, Oil Level	●
Hydraulic, Oil Temperature	●
Lights, Work - Bowl	●
Lockup Clutch	●
Primary Steering Pressure	●
Retarder On	●
Seat Belt	●
Secondary Steering Pressure	●
Stabilizers Down	●
Torque Converter, Oil Temperature	●
Transmission Fault	●
Transmission Filter Bypass	●
Instrumentation, Digital Data	
Computerised Diagnostics and Monitoring	●
Gear and Direction	●
Odometer	●
Service Hour Meter	●
Electrical	
Accessory Power Port (12 V)	●
Alarm, Back-up	●
Alternator, 100 amp	●
Alternator, High Output, 150 amp (Part of Enclosed operator station (FOPS/ ROPS))	●



STANDARD AND OPTIONAL EQUIPMENT

● Standard ● Optional ● Safety

Electrical

Auxiliary Start Receptacle	●
Batteries, Maintenance Free (2x 1400 CCA)	●
Battery Isolation, Lockable Disconnect Switch (2 Pole)	●●
Battery Isolation, (4 Pole)	●●
Beacon, Flashing, LED, Front/Rear of Cab (Amber)	●●
Beacon, Flashing, LED, Front/Rear of Cab (Blue)	●●
Beacon, Flashing, LED, Rear (Amber)	●●
Beacon, Flashing, LED, Rear (Blue)	●●
Beacon, Rotating, Cab, Mounted (Various Colours Available)	●●
Diagnostic Connector	●
Digital Inclinometer Display, Dashboard	●●
Electrical Connectors, Sealed	●
Electronic Monitoring System	●
Emergency Stop - Cabin	●●
Emergency Stop - Ground Level, RH Side, Engine Bay	●●
Emergency Stop - Ground Level, LH Side Front	●●
Emergency Stop - Ground Level, Rear Bowl Control Panel	●●
Emergency Stop - Ground Level, Rear Cab Side with or without Platform	●●
Horn, Warning	●●
Lights, Stop/Tail/Turn	●
Lights, Brake and Tail	●
Lights, Headlights with Dip Switch	●
Lights, Bowl, Rear - Sides of Bowl	●
Lights, Work, Rear - Cab Mounted	●
Lights, Work, Rear - Chute and Control Panel	●
Lights, Work, Rear - Offside/Stair Access	●
Lights, Work, Rear - Top of Bowl Support	●
Lights, Reversing	●
Operator Presence	●●
Starter Isolator, Lockable	●●
Starter Isolator, (4 Pole)	●●
Starter, Electric, Heavy Duty	●
Starting and Charging System (24 V)	●
USB Charger Outlet (5 V)	●

Hydraulics

Bowl Motor with Quick-Connect Lines	●
Brakes, Cooling Filters	●
Brakes, Cooling Oil Coolers	●
Brakes, Separate Cooling Tank	●
Burst Protection, Hoses	●●
Closed Centre, Load Sensing System	●
Hydraulic Oil Cooler	●
Line Filter, Full Flow Return	●

Agitator

Additive Bottle Mount 1x 20 L	●
Additive Bottle Mount 2x 20 L	●
Additive Pump, Manual	●
Bowl Fill - Rear Load to Suit Conveyor	●
Bowl Fill - Top Chute Load to Suit Hopper	●
Bowl, Access Platform/Ladder	●
Bowl, Auxiliary Motor Discharge Hose Kit, Emergency	●
Bowl, Guards (Hitch to Bowl Support)	●●
Bowl, Spray Nozzle, Fixed	●
Bowl, Trunion Guards	●

Agitator

Chute Extension	●
Chute Extension, Placement	●
Rear Stabilisers	●
Tank, Chemical Dosing with Pneumatic Pump, 265 L	●
Tank, Water, 235 L	●
Water Pump, High Pressure, Hose, Reel	●
Water Pump, High Volume, Hose, Reel	●

Other

Anti-Corrosion Protection Spray	●
Articulation Lock Link	●●
Centralised Service Centre (Grouped Filters, Transmission Fill and Engine Fill)	●
Ecology Drains (Hydraulic Tank)	●
Engine, Enclosures, Hinged	●
Film, Gp Reflective, Fluorescent Orange	●●
Film, Gp Reflective, Fluorescent Yellow	●●
Fire Extinguisher, 9 kg, Hand Held Dry Chemical Powder 6A:80B:e LH and RH Side	●●
Fire Suppression System, Ansul A101 Dry Chemical Powder, Engine Shutdown	●●
Fire Suppression System, Sandvik Aqueous-Film Forming Foam, Engine Shutdown	●●
Firewall	●●
Grease Lubrication System, Automatic	●
Grease Lubrication System, Centralised, Manual	●
Guards, Pivoting, Under Engine And Transmission	●
Handrails, Fixed for Top Covers	●
Handrails, Folding for Top Covers	●
Handrails, Painted Contrasting High-visibility Green	●●
Ladder, Folding, Engine Access	●●
Lift, Tie Down and Retrieval Points (Front and Rear)	●
Mudguards	●
Oil Sampling Ports, SOS	●
Radiator Ap, Manual, Anti-scald Pressure Release	●●
Rim Identification	●
Rim, Spare (18.00R25)	●
Steering Lockout, Park Brake Engaged	●●
Steering, Secondary	●●
Tank, Coolant Make Up	●
Tooling - Empty Bowl Lifting	●●
Tooling - Engine Timing	●
Tyre and Rim, Spare (18.00R25)	●
Tyres and Tubeless Rims (18.00R25)	●
Wheel Chocks 2x (Checkers, MC3010)	●●
Wheel Chocks 2x (Checkers, UC1210)	●●
Wheel Nut Retention Indicators	●●

OVER 45 YEARS IN THE MINING INDUSTRY.

Elphinstone Pty Ltd is an established Caterpillar Original Equipment Manufacturer with over 45 years' experience in the mining industry. Elphinstone specialises in the design, manufacture and support of quality equipment for the global underground and surface mining industries.

The Elphinstone range of Underground Mining Support Vehicles combines practical design, the latest technology and quality manufacturing to ensure reliable performance.

The current product range includes specialised underground support vehicles, mine extraction devices, extended distance off-highway haulage trucks and water tanks customised to suit Caterpillar articulated trucks.

As an authorised Caterpillar Original Equipment Manufacturer, all Elphinstone products are sold and supported via the global Cat® dealer network.

WR820 AGITATOR 8M³

For more complete information on Elphinstone products, dealer services, and industry solutions, visit www.elphinstone.com or contact your local Cat dealer.

Material and specifications are subject to change without notice. Featured machines in photos may include additional equipment.

Elphinstone and their respective logos, as well as corporate and product identity used herein, are trademarks of Elphinstone and may not be used without permission.

© 2024 Elphinstone. All rights reserved.
Made in Australia for export.

ELPHINSTONE



HM06712-02 (01-2024)