



E10
FUEL & LUBE



Elphinstone Underground Support Solutions
elphinstone.com

ELPHINSTONE

UNDERGROUND RELIABILITY



**E10 UNDERGROUND
FUEL & LUBE**





SERVICE TOP-UP CAPABILITY AND RELIABLE PERFORMANCE.

Machine Safety

With safety as a priority, the E10 is engineered with onboard machine diagnostics for rapid fault identification, increasing the availability and productivity of the machine. The certified ROPS/FOPS air-conditioned operator cabin seats three persons comfortably. The ergonomic controls, excellent visibility, and LED lighting increase safety and reduce operator fatigue. The oscillating hitch, front suspension (optional) and air-ride seats provide unrivalled comfort for the operator. The electro-magnetic braking retarder, adjustable from the operator's seat, provides superior and reliable braking capability.

Maintenance and Serviceability

A forward-tilting cabin, swing-out radiator grill, hinged engine bonnet cover, and hinged exhaust module, provide safe access for maintenance. Ground level access to service points reduce risk and time spent checking the machine status.

Machine Application

The E10 chassis is a multipurpose platform designed for various underground mining applications. The E10 Fuel & Lube provides in situ top-up of lubricants, greasing, and refuelling of production machines, eliminating the need to leave the work area. Maintaining production machines in their respective work areas reduces traffic on the haul routes leading to increased productivity. The rear module houses all pump controls and dispensing units in a central location at ground level.

Contents

Structures, Work Tools and Attachments	4
Operator Environment	6
Safety Features	7
Engine	8
Powertrain	9
Product Features	10
Customer Support	12
Sustainability	12
Maintenance and Serviceability	13
Technical Specifications	14
Machine Dimensions	15
Standard and Optional Equipment	16
Your Notes	18



DELIVERING FUEL AND LUBE SERVICE TOP-UP CAPABILITY.

Machine application

- » Provides in situ top-up of lubricants, greasing, and refuelling of production machines within the mine.
- » Eliminates the need for production machines to leave the work site, in turn reducing traffic on the haul roads.
- » Excellent top speed at full capacity improves the cycle time and allows the machine to travel at the same speed as the production fleet resulting in increased production.

Fluid metering and dispensing

The E10 Fuel & Lube is fitted with a 5000L (1,320 gal) fuel tank that incorporates a diesel fast fill connection, fluid level indicators, and an air-operated fuel pump. The diesel nozzle features a digital LCD screen with internal battery power supply, a 19mm (0.75in) curved outlet spout, and automatic shut off on back pressure. The digital readout provides multiple measuring units (litres and gallons) with a rated fluid delivery of approx. 60L/min (15.8 gal/min). Located between the fuel tank and service module are four 300L (79 gal) oil tanks (Engine, Hydraulic, Transmission and Waste oils) all incorporating fluid level indicators, fast fill/evacuation fittings, and an air-operated oil pumps. The oil nozzle features digital LCD screen with internal battery power supply, flexible extension and multiple measuring unit readouts (litres and gallons) and a rated oil delivery of 8L/min (2.1 gal/min). Also included is a 55kg (121lbs) bulk grease drum with air-operated grease pump.

Service module

The service module is located at the rear of the machine providing easy access to all services. Features include:

- » Air operated diesel & waste oil diaphragm pumps.
- » Fluid dispenser storage rack with bunded spill tray.
- » Oil nozzle with digital meter.
- » Diesel nozzle with digital dispenser.
- » 4.5kg (10lb) Dry chemical powder fire extinguisher.
- » Air compressor (screw type).
- » Inline air filter/water separator and regulator.
- » Heavy duty spring return hose reels.
- » Oil and fuel supply filters.
- » Pump control panel.
- » Reverse camera.
- » Service control panel.

Service control panel

Located on rear left hand side of the machine, the service control panel includes controls for the air compressor and rear work lights, pressure gauge to monitor air compressor output, E-stop, and fire suppression actuator (optional).

Pump control panel

Located on rear right hand side of the machine, the pump control panel controls the air supply to each pump mounted to the individual tanks. An air dump valve is used to bleed the air from the system.



STRENGTH AND SUPERIOR BRAKING PERFORMANCE.

Heavy duty front frame

The robust, heavy-duty, and purpose design front frame utilises a high tensile steel construction with an average plate thickness of 20mm (0.80in). The frame design is common to both front and centre-mounted operator cabin options, both engine options and the option of front suspension or rigid axle. The front suspension mounting points and fuel tank are incorporated into the common frame. The frame includes an access cover for cleaning and inspecting the fuel tank if required.

Rear frame and deck

The rear frame uses high tensile steel box section construction with an average thickness of 12mm (0.47in). The deck features integrated spill bunding channels for containing fluid spills. The deck is constructed with a combination of high strength steel sections and steel plate.

Fuel and oil tanks

Each tank features integrated lifting points for easy removal when the tank is empty. Rubber isolation mounts are used to cushion and reduce transfer of vibration. The diesel tank is baffled to reduce fluid surging when in transit and improve tank strength.

Oscillating hitch

The oscillating hitch provides superior operator comfort, 4-wheel ground contact and reduced wear on the hitch and steering components. Includes a heavy duty 600mm (1ft 11in) deep frame section through oscillating hitch area with +/- 42.5° steering articulation and +/- 10° oscillation.

Electro-magnetic retarder

Fitted to the rear frame, the electronically controlled retarder provides superior braking performance on grade, featuring diagnostic capabilities with alarm and fault conditions reported back to the operator display. The integrated Retarder Control System (iRCS) combines both the control and power functions into a single unit. The innovative electronic design significantly reduces the retarder's energy consumption, preserving electric circuits. The retarder is controlled via an integrated multi-function joystick controller located on the operator's right-side armrest.

Other features include

- » Provision for additional 2x oil/coolant tanks can be optioned if the drums are not required.
- » 2x 2-point lashing devices for drum storage.
- » Service area when drums removed.
- » Open and enclosed storage compartments.
- » Diesel tank isolation valve.
- » Manual diesel fill point on top of the tank.
- » Hand wash reservoir and soap dispenser.
- » Fuel tank inspection/cleaning cover.
- » Manual oil tank fill point on top of each tank.
- » Breather for fast fill to balance tank pressure.
- » Individual air operated oil pumps.
- » Air-operated grease pump.



COMFORTABLE AND EASY TO OPERATE.

Two cabin configurations available

Fitted with a standard 3-seat open cabin, the E10 is also available with an optional air-conditioned, 3-seat enclosed cabin (pictured above). The enclosed cabin features ergonomics for operator comfort, user-friendly intuitive controls, and excellent 360-degree visibility.

The cabin includes the following features:

- » ROPS/FOPS certified design.
- » 300mm (12in) touch screen operator display.
- » Fingertip controls mounted to operators seat.
- » 3 full size seats. Air-ride suspension seat standard for driver, non-suspended seats for occupants. Optional Air-ride suspension seats for all persons.
- » Air conditioning and optional cab pressurisation.
- » Seat belts with occupant detection systems (operator seat).
- » Forward tilting cab for ease of maintenance.
- » Emergency stop inside cab.

Integrated multi-function joystick controller

The operator's right arm rest features an integrated multi-function joystick controller providing finite control in transit for speed and machine braking performance.

Transmission controls

The keypad transmission control is conveniently located near the operator's right hand, with forward and reverse gears changed effortlessly with finger touch accuracy reducing driver fatigue.

Seating arrangements

The standard seating arrangement includes a centre driving position with two additional trainer/work-crew seats. The driver's seat is a 'T' seat with air suspension, and the crew seats are a standard 'T' seat or optional 'T' seat with air suspension. A storage compartment is optional if trainer/work-crew seating is not required. Retractable seat belts are standard with an occupancy indicator alarm system available as an option. The alarm is activated if the seat belt is not fastened as the machine brakes are released.

Steering column

The steering column can be adjusted to an ergonomic position for maximum operator comfort by tilting or extending the column.

Tilted cab mounting

The cabin is resiliently mounted to the machine chassis, reducing vibration for greater operator comfort and a quieter ride. The cabin tilts and locks into position with supports for safe and easy maintenance.

Touch screen operator display

The 300mm (12in) touch screen displays vital machine status information. Data collected includes engine coolant and transmission oil temperature, pitch and roll indicators, engine oil pressure, engine speed, an integrated camera system (up to 4x), and vehicle speed and fuel level.

Machine health monitoring system

The monitoring system and alarm strategy provides a 3-tier warning and shutdown functionality alerting the operator of any abnormalities and automatically limits the machine's functions.



SAFETY FEATURES



OPERATOR SAFETY IS OUR PRIORITY.

Product safety

The E10 Fuel & Lube is designed with safety as a priority.

Machine isolation

All engine and machine isolation functions are conveniently located on one panel accessible from ground level. Switches have been designed to incorporate the requirement for the site tag in/out machine isolation process.

- » Battery isolation switch.
- » Starter isolation switch.
- » Jump start receptacle.
- » Fire system activation (optional).

Cabin protective structure

The operator cabin has an integrated Rollover Protective Structure (ROPS) certified to ISO 3471:2008 and Falling Object Protective Structure (FOPS) certified to ISO 3449:2005.

Handrails

Handrails are fitted standard in accordance with ISO 2867:2011. All handrails are painted green and designed for 3-point access to cab and machine.

Steering

Full hydraulic controlled steering via opposed cylinders at the oscillating hitch. Secondary emergency steering is also provided as standard.

Braking

Service brakes are hydraulic applied wet disc brakes. Emergency brakes are spring applied hydraulic release at the wheel ends. Braking systems meet ISO 3450:2011.

Additional safety features

- » Anti-skid step surfaces.
- » Inertia reel retractable seat belt.
- » Steering frame lock.
- » Electrical wiring segregation from all hydraulic hosing.
- » Fire resistant wiring.
- » Firewall / heatshields.
- » Machine interlocks (Battery and Starter) for additional protection.
- » Integrated fire suppression systems (optional).
- » Hydraulic hosing covered with burst protection sleeves.
- » Door ajar warning (Operator Presence) systems.
- » Door lighting for better step visibility.
- » Window egress cord for ease of cab window removal.
- » Rear view camera.
- » Park brake interlocking.
- » Whilst compressor is in use, the park brake is interlocked.

Ground level servicing access

Allows convenient servicing to tanks, filters, lubrication points and compartment drains.



DELIVERS POWER, PERFORMANCE AND DURABILITY.

C7.1 engine

The Cat C7.1 uses Caterpillar's breakthrough ACERT™ Technology to meet exhaust emission reduction standards. It features efficient fuel delivery, air management and electronic control for high productivity and exceptional service life.

The C7.1 ACERT Tier 3 engine arrangement rated at 168 kW (225 hp) is standard for regions that may not have Ultra Low Sulphur Fuel or more stringent emission regulations. An optional diesel particulate filter can be fitted.

The C7.1 ACERT Tier 4 Final engine arrangement is available as an option, adhering to EU Stage V exhaust emission standards. This arrangement is offered in a dual horsepower configuration and can be set at 151kW (202hp) for the higher performance rating or the lower reduced ventilation rating at 129kW (173hp) through a simple software change performed by your Caterpillar Dealer.

ADEM A4 engine control module

The ADEM A4 module controls the fuel injector solenoids to monitor fuel injection. It also provides automatic altitude compensation, and will not allow the engine to start until it has oil pressure, acting as cold start protection and a form of pre-lube.

Maintenance

The C7.1 engine reduces costs and downtime with 500-hour oil change intervals. The E10 is equipped with Caterpillar high efficiency oil filters, a design which doubles efficiency without increasing the change interval.

Engine protection system

An engine protection system is fitted that will shut down the engine if low engine oil pressure, low coolant level, or coolant over temperature conditions are experienced.

Commonality

The Caterpillar C7.1 engine is found in several Caterpillar products and applications such as Medium Wheel Loaders, Excavators, Motor Graders, Marine and Industrial services. This means the E10 shares component commonality across many applications, providing the highest level of reliability and durability, as well as superior parts availability worldwide through the Caterpillar Dealer Network.





PERFORMANCE AND RELIABILITY IN TOUGH CONDITIONS.

Caterpillar five-speed transmission

The field proven Cat power shift countershaft transmission easily matches engine power to the load size and ground conditions. Gear changes are simplified with ergonomically positioned electronic fingertip controls, reducing operator fatigue.

Electro-magnetic retarder

Fitted to the rear frame, the electronically controlled retarder provides superior braking performance on grade, featuring diagnostic capabilities with alarm and fault conditions reported back to the operator display. The integrated Retarder Control System (iRCS) combines both the control and power functions into a single unit. The innovative electronic design significantly reduces the retarder's energy consumption, preserving electric circuits. The retarder is controlled via an integrated multi-function joystick controller located on the operator's right-side armrest.

Reduced shifting

The multiplication capability of the torque converter reduces the need for the operator to continually shift the transmission. This reduces operator effort and improves machine productivity.

All wheel drive (AWD)

All-wheel drive provides excellent power distribution, increases traction of the machine reducing tire slippage, improving performance, handling and manoeuvrability in tough and challenging terrain.

Front and rear axles

The front axle is rigid mounted design with front suspension available as an option. The rear axle is rigidly mounted to the rear frame.

Tyres

Tyres are an integral part in a machines ability to carry it's load at higher speeds. Fitted with the larger 14:00 R20 Radial tires ensures the E10 stays within the tires TKPH limits. This allows the E10 to carry larger loads at faster speeds than conventional utility equipment.

Service brakes

Hydraulically applied spring release brake system. Brake components are oil immersed inside the axles, protecting them from contamination. Modulated braking provides smooth deceleration for precision stopping and operator control.

Parking brake

The parking brake is a spring applied oil released "fail to safe" enclosed wet disc on all 4-wheel ends.

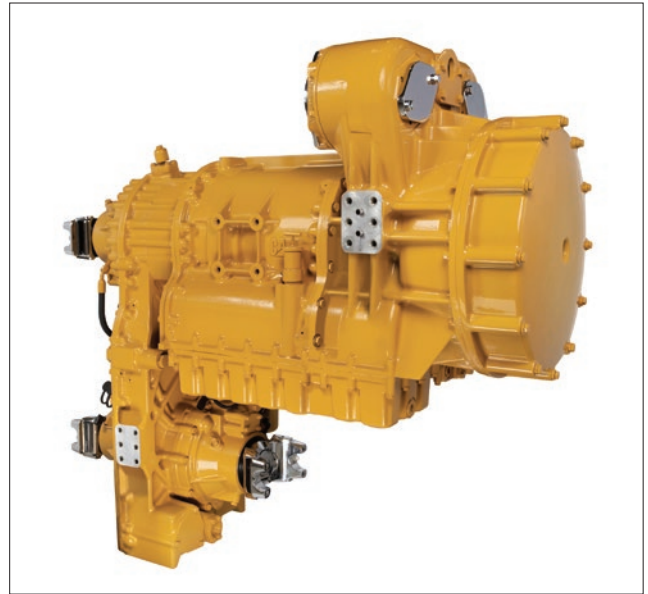

Brake design

With large discs and plates for reliable, adjustment free operation and performance. Oil cooled disc brakes are completely enclosed to prevent contamination and reduce maintenance.

Emergency braking

When the E10 safety system detects loss of critical drive pressure or brake pressure the operator will receive a warning and then the parking brake system will be safely apply.

Load sensing

A load sensing variable displacement pump and pressure compensating system continually monitor hydraulic power requirements, then provides power based on demand. This improves fuel economy and reduces emissions.

Other features include suction circuits, pump case-drain and steering return, filtered fan/brake pressure circuit, and closed loop hydraulic system.



FEATURE OVERVIEW

INCREASED PRODUCTIVITY & RELIABILITY WITH FUEL & LUBE TOP-UP CAPABILITY.

● Standard ● Optional ● Safety

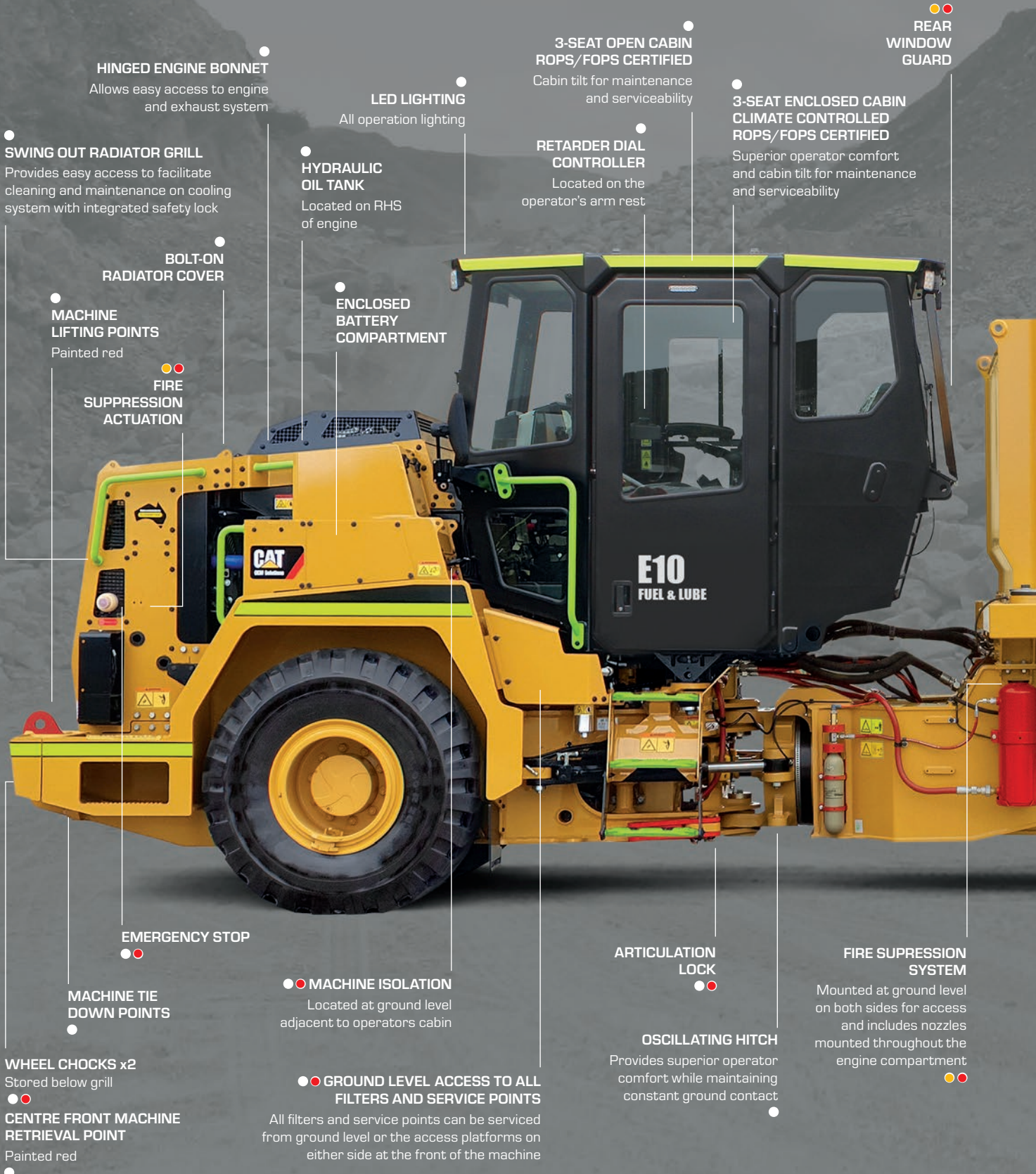

HINGED ENGINE BONNET
Allows easy access to engine and exhaust system

LED LIGHTING
All operation lighting

3-SEAT OPEN CABIN
ROPS/FOPS CERTIFIED
Cabin tilt for maintenance and serviceability

REAR WINDOW GUARD

SWING OUT RADIATOR GRILL
Provides easy access to facilitate cleaning and maintenance on cooling system with integrated safety lock

HYDRAULIC OIL TANK
Located on RHS of engine

RETARDER DIAL CONTROLLER
Located on the operator's arm rest

3-SEAT ENCLOSED CABIN
CLIMATE CONTROLLED
ROPS/FOPS CERTIFIED
Superior operator comfort and cabin tilt for maintenance and serviceability

BOLT-ON RADIATOR COVER

ENCLOSED BATTERY COMPARTMENT

MACHINE LIFTING POINTS
Painted red

FIRE SUPPRESSION ACTUATION

E10
FUEL & LUBE

EMERGENCY STOP

MACHINE TIE DOWN POINTS

MACHINE ISOLATION
Located at ground level adjacent to operators cabin

ARTICULATION LOCK

FIRE SUPPRESSION SYSTEM
Mounted at ground level on both sides for access and includes nozzles mounted throughout the engine compartment

WHEEL CHOCKS x2
Stored below grill

GROUND LEVEL ACCESS TO ALL FILTERS AND SERVICE POINTS

OSCILLATING HITCH
Provides superior operator comfort while maintaining constant ground contact

CENTRE FRONT MACHINE RETRIEVAL POINT
Painted red

All filters and service points can be serviced from ground level or the access platforms on either side at the front of the machine



HAND WASH RESEVOIR AND SOAP DISPENSER
Located on RHS

FLUID LEVEL INDICATORS
Located on RHS of diesel fuel tank

DIESEL FAST FILL
Located on RHS of fuel tank

5000 L (1320 GAL) DIESEL FUEL TANK
Baffled to reduce fluid surging when in transit and improve tank strength. Includes inspection cleaning hatch

MODULE LIFTING POINTS

4x 300 L (79 GAL) OIL TANKS
Colour coded labels for engine, hydraulic, transmission and waste oil

OIL FAST FILL AND EVACUATION
Located on RHS of oil tanks

FLUID LEVEL INDICATORS
Located on RHS of all five oil tanks (engine, hydraulic, transmission, diesel and waste)

INDIVIDUAL AIR-OPERATED OIL PUMPS

AIR-OPERATED GREASE PUMP

MODULE LIFTING POINTS

SERVICE MODULE ENCLOSURE
Includes oil reels, air compressor and pump controls

ELPHINSTONE

CAT

CAT

AUTO LUBRICATION PUMP
Automatically supplies grease to all lubricating points on machine mounted at ground level for access

ELECTRO-MAGNETIC BRAKING RETARDER
Adjustable from the operator's seat, provides superior and reliable braking capability

OPEN STORAGE COMPARTMENT
Located on both sides

2x DRUM STORAGE WITH 2-POINT LASHING DEVICE

3-PIECE WHEEL RIMS

ENCLOSED STORAGE COMPARTMENT
Located on both sides

PROVISION FOR 2x ADDITIONAL OIL/COOLANT TANKS
If drums are not required

TIE DOWN LIFT POINT
Painted red

CENTRE REAR MACHINE RETRIEVAL POINT
Painted red

OPEN STORAGE COMPARTMENT
Located on both sides



CUSTOMER SUPPORT

WHEN UPTIME REALLY COUNTS.

Renowned Cat dealer support

From helping you choose the right machine to financing and ongoing support, your Cat dealer provides the best in sales and service.

- » Manage your costs with preventive maintenance programs like SOS™ fluids analysis, coolant sampling.
- » Stay productive with best-in-class parts availability.
- » our Cat dealer can also help you boost efficiency with operator training.
- » When it's time for component replacement, your Cat dealer can help you save even more. Genuine Cat remanufactured parts carry the same warranty and reliability as new products at savings of 40 to 70 percent for powertrain and hydraulic components.
- » Technical training and maintenance planning are also part of the Dealer offerings.
- » Would you like the Dealer to do more? Programs such as Customer Service Agreements, to a full Maintenance and Repair contract are available.



FUTURE SUSTAINABILITY

THINKING INTO THE FUTURE.

Sustainable waste and cost management

- » Integrated machine systems and technologies improve productivity for greater accuracy, lower fuel use and reduce machine wear.
- » Replaceable wear parts save maintenance time and cost and extend major component life.
- » Ecology drains help make draining fluids more convenient and help prevent spills.
- » Major components are built to be rebuilt, eliminating waste and saving customers money by giving the machine and/or major components a second – and even third life rebuilds.
- » A variety of safety features help safeguard operators and others on the job.





SERVICEABILITY MEANS MORE TIME FOR PRODUCTION.

Engine access

Forward tilting cabin, swing out radiator grill, hinged bonnet and exhaust module make regular maintenance quick and easy. Easy access to daily service points increases the likelihood that maintenance will be done resulting in increased machine service life. In addition, less maintenance time means more working time and greater productivity.

Frame access

Steps and grab handles positioned for 3-point contact are standard for easy access to the service and operation areas.

Bolt-on guards

Bolt-on guards offer protection to critical components and are easily removable for servicing. Removable floor plates and side plate allow access to components under the cab.

Air filters

Air filters are easy to change, reducing air filter maintenance times.

Extended oil service intervals

A 500-hour oil change interval reduces downtime for service and lowers maintenance costs.

SOS™ fluid sampling valves

Provides a fast, convenient way to gather uncontaminated fluid samples, which improves analysis reliability.

Pressure taps

Conveniently located for easy access to hydraulic system pressure measurements.

Electrical system

The 24V electrical system delivers a reliable electrical capacity for engine starting and additional lighting. Wiring circuits are colour coded and numbered for easy diagnosis and repair. All circuits are protected by circuit breakers. Wiring is double insulated with sealed electrical connectors to prevent moisture and dirt access. Harnesses are covered with fire resistant material for additional protection.

On-board diagnostic systems

The monitoring system continuously checks all critical machine functions and components and helps locate faults quickly for faster repair.

Hitch hoses

- » The pilot hoses, pressure line and load sense lines have all been routed above the hitch and bulk-headed for easy hose replacement and fast service.
- » Spin-on oil filters.
- » Spin-on fuel and engine oil filters shorten downtime.
- » Electronic transfer pump eliminates the need to manually prime the fuel system.

Centralised service centre

A centralised service centre that includes fast fill and evacuation points (optional).



TECHNICAL SPECIFICATIONS

Engine

Engine Tier	Tier 3 - Standard		Tier 4 Final (Low Power)		Tier 4 Final (High Power)	
Engine Model	Cat C7.1 ACERT (TA)		Cat C7.1 ACERT (TA)		Cat C7.1 ACERT (TA)	
Gross Power SAE J1995	168 kW	225 hp	129 kW	173 hp	151 kW	202 hp
Displacement	7.0131 L	428 in3	7.0131 L	428 in3	7.0131 L	428 in3
Bore	105 mm	4.1 in	105 mm	4.1 in	105 mm	4.1 in
Stroke	135 mm	5.3 in	135 mm	5.3 in	135 mm	5.3 in
Number of Cylinders	6		6		6	
Max Torque @ Rated Speed	1028 Nm @ 1400 rpm		842 Nm @ 1400 rpm		870 Nm @ 1400 rpm	
Derating Altitude	3000 m	9843 ft	3000 m	9843 ft	3000 m	9843 ft
Emission Certification	EPA Tier 3		EPA Tier 4 Final		EPA Tier 4 Final	
Alternator	150 amp		150 amp		150 amp	
Electrical System	24 V		24 V		24 V	
Battery - Quantity	2		2		2	
Battery - Volts	12 V		12 V		12 V	
Battery - Capacity	1000CCA		1000CCA		1000CCA	
Starting System	Direct Electric		Direct Electric		Direct Electric	

- Power ratings apply at 2200 rpm when tested under the specified standard conditions.
- Based on standard air conditions of 25° C (77° F) and 99 kPa (29.32 in Hg) dry barometer. Used 35° API gravity fuel having an LHV of 42,780 kJ/kg (18,390 BTU/lb) when used at 30° C (860 F) [ref. A fuel density of 838.9 g/L (7.001 lb/gal)].

Powertrain

Travel Speed - Fwd. 1st	5.7 km/h	3.5 mph
Travel Speed - Fwd. 2nd	9.4 km/h	5.8 mph
Travel Speed - Fwd. 3rd	15.0 km/h	9.3 mph
Travel Speed - Fwd. 4th	20.0 km/h	12.4 mph
Travel Speed - Fwd. 5th	32.2 km/h	20.0 mph
Travel Speed - Rev. 1st	5.7 km/h	3.5 mph
Travel Speed - Rev. 2nd	9.4 km/h	5.8 mph
Travel Speed - Rev. 3rd	20.0 km/h	12.4 mph
Torque Converter Type	Lock-up clutch	
Transmission	5 fwd / 3 rev countershaft powershift	
Steering, Frame Articulation	42.5 degrees	
Brakes - Service Type	Hydraulic applied inboard WET disc enclosed	
Brakes - Parking Type	Internal Spring Applied Hydraulically Released wheel ends (SAHR)	
Tyres	14.00 R20	

Service Refill

Fuel Tank	340 L	89.8 gal
Cooling System	50 L	13.2 gal
Differential, Final Drive - F	18.5 L	4.9 gal
Differential, Final Drive - R	18.5 L	5.4 gal
Engine Oil	13.5 L	3.6 gal
Transmission, Torque Converter	31 L	8.2 gal
Hydraulic Tank	150 L	39.6 gal
Diesel Exhaust Fluid (DEF) (Tier 4 Final Only)	16 L	4.2 gal

Standards

ROPS/FOPS	ISO 3471:2008 / ISO 3449:2005
Steering	ISO 5010:2007
Braking	ISO 3450-2011/CSA-M424.3-M90

Weights

Gross Vehicle Weight (GVM)	24,750 kg	54,564 lb
Tare Weight	18,480 kg	40,741 lb

*Tare weight includes one operator and a full tank of fuel.

Speed on Grade

Cat C7.1 ACERT, 168kW Tier 3

Grade	Vehicle Speed (km/h)				
	1st Fwd	2nd Fwd	3rd Fwd	4th Fwd	5th Fwd
1:7 (14%) Empty (18,480 kg)	5.7	9.4	15.0	18.2	-
1:7 (14%) GVM (24,740 kg)	5.7	9.4	13.7	-	-

Cat C7.1 ACERT, 151kW Tier 4 Final (High Power)

Grade	Vehicle Speed (km/h)				
	1st Fwd	2nd Fwd	3rd Fwd	4th Fwd	5th Fwd
1:7 (14%) Empty (18,480 kg)	5.7	9.4	15	16.4	-
1:7 (14%) GVM (24,740 kg)	5.7	9.4	12.3	-	-

Cat C7.1 ACERT, 129kW Tier 4 Final (Low Power)

Grade	Vehicle Speed (km/h)				
	1st Fwd	2nd Fwd	3rd Fwd	4th Fwd	5th Fwd
1:7 (14%) Empty (18,480 kg)	5.7	9.4	13.7	13.7	-
1:7 (14%) GVM (24,740 kg)	5.7	9.4	10.3	-	-

*Note: 2% rolling resistance

Service Module

Dispenser, Diesel, Auto Shut-off with Digital Metering	60 L/min flow rate	15.8 gal/min flow rate
Dispensers, Oil, Manual with electronic metering		
Hose Reels, Rear Mounted	Spring rewind	
Provision for 2X 55 Gallon Drums	205 L	55 gal
Pump, Air Operated for Engine, Transmission, and Hydraulic Oil Dispensing Systems		



MACHINE DIMENSIONS

Turning Radius

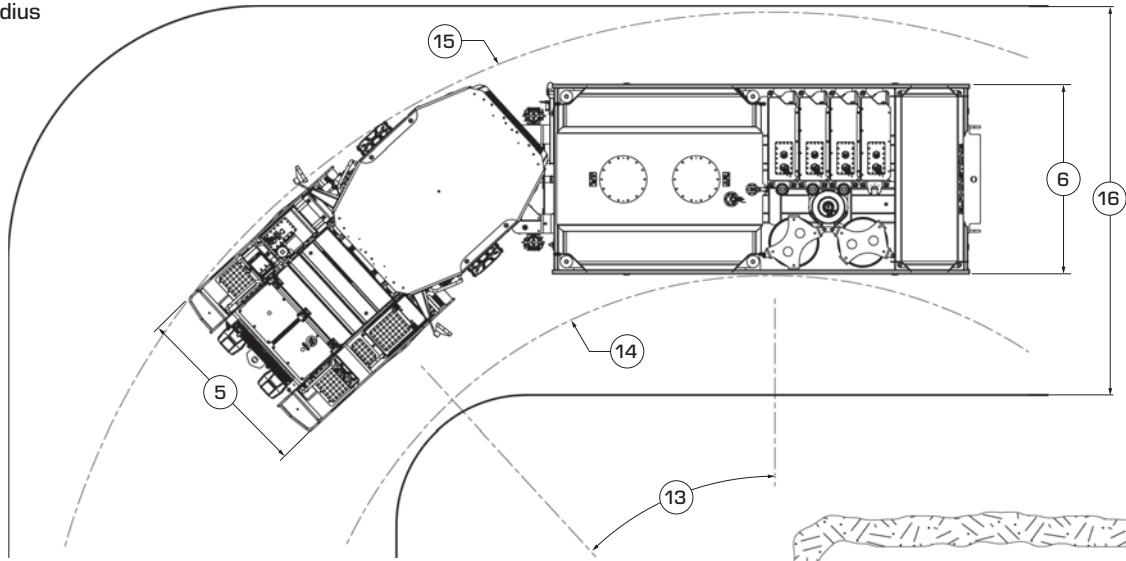

Side View and Drive Size

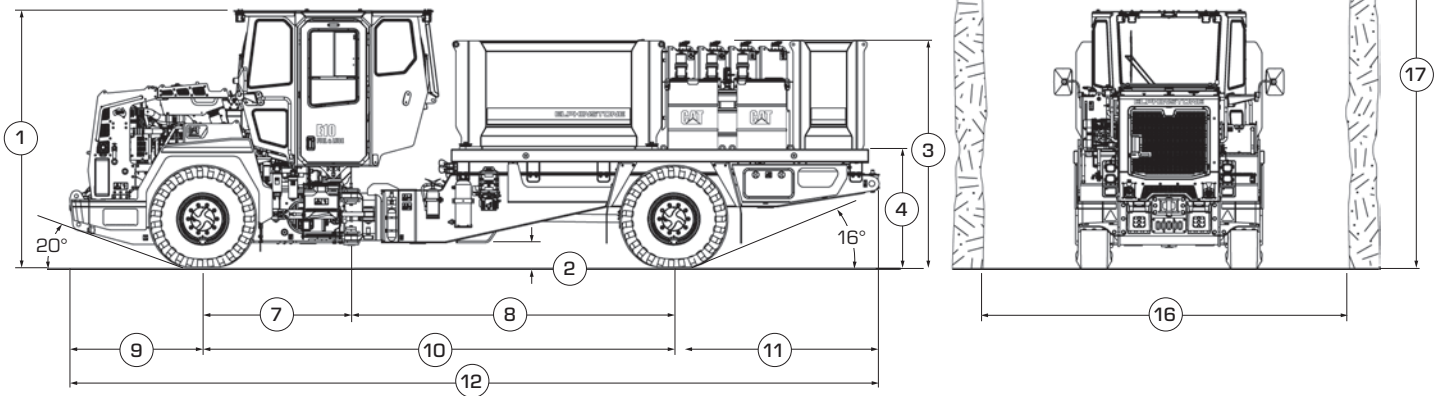

Service Module

Pump, Air Operated, Bulk Grease Pumping System to suit 55kg Grease Drum		
Pump, Air Operated, Diaphragm for Diesel Dispensing System		
Pump, Air Operated, Diaphragm for Waste Oil System		
Tank, Diesel	5000 L	1320 gal
Tank, Engine Oil	300 L	79 gal
Tank, Hydraulic Oil	300 L	79 gal
Tank, Transmission Oil	300 L	79 gal
Tank, Waste Oil	300 L	79 gal
Reservoir, Fluid, Resiliently Mounted		
Reservoir, Hand Wash, Includes Soap Dispenser	23 L	6 gal
Storage Compartments	2x Enclosed, 4x Open	
Onboard Air Compressor		
Compressor circuit	Includes filter, regulator, lubricator & pressure gauge	
Compressor Type	Screw	
Max Flow Rating	1300 L/min	343 gal/min
Max Pressure	10 bar	

Dimensions

1	Height - Top of Cabin	3000 mm	9 ft 10.1 in
2	Height - Ground Clearance	305 mm	1 ft 0 in
3	Height - Top of Tank	2650 mm	8 ft 8.3 in
4	Height - Top of Deck	1390 mm	4 ft 6.7 in
5	Width - Machine Front Frame	2100 mm	6 ft 10.6 in
6	Width - Machine Rear Frame	2200 mm	7 ft 2.6 in
7	Length - Front Axle to Hitch	1725 mm	5 ft 7.9 in
8	Length - Hitch to Rear Axle	3750 mm	12 ft 3.6 in
9	Length - Front axle to bumper	1545 mm	5 ft 1 in
10	Length - wheel base	5475 mm	17 ft 11.6 in
11	Length - Rear Axle to bumper	2385 mm	7 ft 9.9 in
12	Length - Overall	9405 mm	30 ft 10.3 in
13	Articulation	42.5 deg	

Drive Size

14	Radius - Inside Clearance - By design	5546 mm	18 ft 2.34 in
15	Radius - Outside Clearance - By design	8603 mm	28 ft 2.7 in
16	Minimum Width Portal (90° corner)	4500 mm	14 ft 9.1 in
17	Typical Minimum Height Portal	4500 mm	14 ft 9.1 in



STANDARD AND OPTIONAL EQUIPMENT

● Standard ● Optional ● Safety

Powertrain

Air Cleaner, 2-Stage With Integral Pre-Cleaner	●
All Wheel Drive with Lock-up Torque Converter	●
Axle Breathers, Remote Mounted	●
Brakes - Parking, Four Wheel Spring Applied, Enclosed Disc	●
Brakes - Service, Four-Wheel Pressure Applied Enclosed Disc	●
Brake - Driveline, Electromagnetic Retarder	●
Driveline Slip-joint, Lubed for Life	●
Engine, Cat C7.1, ACERT Technology, ATAAC - Tier 3	●
Engine, Cat C7.1, ACERT Technology, ATAAC - Tier 4 Final	●
Fan, Sucker	●
Filters, Engine Air, Primary/Secondary	●
Filters, Fuel, Primary/Secondary	●
Final Drives, Outboard Planetary	●
Fuel Transfer Pump (Electric)	●
Fuel Lines - Double Wire Braided	●
Fuel Shutoff Valves Supply & Return	●
Lock - Wheel Nut (Torque Retention)	●
Muffler/Catalytic Converter (Tier 3 Only)	●
Oscillating Hitch	●
Radiator	●
Steering, Rotary Metering Pump	●
Suspension, Front Axle	●
Transmission, Countershaft Powershift (5F/3R)	●
Universal Joints, Lubed for Life	●
Fast-Fill Systems	
Coolant, Engine Oil, Hydraulic Oil, Transmission Oil	●
Fuel, Non-pressurised	●

Antifreeze

Coolant, Extended Life for -35°C (-30°F)	●
Coolant, Arctic Extended Life for -50°C (-58°F)	●

Operator Environment

300 mm (12 in) Touch Screen Operator Display	●
Brake Retarder Control	●
Cabin, Open, FOPS/ROPS	●
Cabin, Enclosed, FOPS/ROPS, Climate Control Modular 24 V HVAC System, Sliding Door Window	●
Cabin, Pressuriser	●
Cabin, Rear Window Wiper and Washer	●
Cabin, Tilt Supports	●
Cabin, Tilt Supports, Reduced Height	●
Cabin, Window Guard, Rear	●
Camera/Monitor, Reversing	●
Diagnostic Connector	●
Engine Idle Timer	●
Fire Extinguisher 2.5 kg, Hand Held Dry Chemical Powder 3A:40B:E LH Side	●
Fire Extinguisher 2.5 kg, Hand Held Dry Chemical Powder 3A:40B:E RH Side	●
Interior Lamps (LED)	●
Mirrors, Rear View	●
Occupancy Indicator, Operator	●
Seat Belt, 3x Retractable	●
Seat, T-Seat, Air Suspension, Operator	●

Operator Environment

2x Seat, T-Seat, Air Suspension, Companion	●
Seat Covers, Operator and Companion	●
Steering Wheel, Tilt and Telescoping	●
Instrumentation, Gauges	
Brake, Accumulator Pressure	●
Brake, Oil Pressure	●
Diesel Exhaust Fluid (DEF) (Tier 4 Final Only)	●
Engine, Coolant Temperature	●
Engine, Oil Pressure	●
Fuel, Level	●
Hydraulic, Oil Temperature	●
Pressuriser Air Filter, High Efficiency Particulate Air	●
Pressuriser Air Filter, Activated Charcoal	●
Speedometer	●
Steering, System Pressure	●
Tachometer	●
Torque Converter, Oil Temperature	●
Instrumentation, Warning Indicators	
Brake, Accumulator Oil Pressure	●
Brake, Fault	●
Brake, Park Indicator	●
Cabin, Door Open	●
Electrical System	●
Emergency Stop	●
Engine, Coolant Temperature	●
Engine, Fault	●
Engine, Oil Pressure	●
Hydraulic, Oil Level	●
Hydraulic, Oil Temperature	●
Steering, Primary	●
Steering, Secondary	●
Torque Converter, Oil Temperature	●
Transmission, Fault	●
Transmission, Oil Filter Bypass	●
Instrumentation, Digital Data	
Gear and Direction	●
Driveline Retarder, Braking Percentage	●
Service Hour, Meter	●
Electrical	
Accessory Power Port (12 V) & (24 V)	●
Alarm, Back-up	●
Alternator, 150 amp	●
Auxiliary Start Receptacle	●
Batteries, Maintenance Free (2x1000 CCA)	●
Battery Isolation, Lockable Disconnect Switch (4 Pole)	●
Diagnostic Connector	●
Emergency Stop - Cabin	●
Emergency Stop - Ground Level, LH Side Front	●
Emergency Stop, Additional, RH Side Front	●
Horn, Warning	●
Lights, Beacon (LED), Cab Mounted (Amber/Red/Blue)	●
Lights, Headlights (LED)	●
Lights, Reversing	●
Lights, Stop/Tail/Turn (LED)	●
Lights, Work, Front/Rear - Cab Mounted (LED)	●



STANDARD AND OPTIONAL EQUIPMENT

● Standard ● Optional ● Safety

Electrical

Lights, Work, Front/Rear - Cab Mounted (LED) Additional	●
Radio, Ready, Communications	●
Radio, AM/FM/USB/Bluetooth	●
Sealed Electrical Connectors	●
Starter, Electric, Heavy Duty	●
Starter Isolator, Lockable Disconnect Switch (4 Pole)	●
Starting and Charging System, 24 V	●

Hydraulics

Case Drain Return Screen	●
Closed Center-load Sensing System	●
Hydraulic Oil Cooler	●
Hydraulic Oil Filling System, Filtered	●
Line Filter, Full Flow Return	●
Suction Screen	●

Service Module

Dispenser, Diesel, Auto Shut-Off with Digital Metering, 60 L/min Flow Rate	●
Dispensers, Manual Oil with Electronic Metering	●
Compressor Circuit includes Filter, Regulator, Lubricator & Pressure Gauge	●
Filtered Oil Dispensing System using Caterpillar Ultra High Efficiency Spin-On Filters	●
Heavy Duty Bunded Deck	●
Hose Reels, Rear Mounted, Spring Rewind	●
Lights, Work, Rear, (LED) 2x	●
Lights, Work, Rear, Dome, (LED) 2x	●
Onboard Air Compressor, Screw Type, Max Flow Rating 1300 L/min, Max Pressure 10 bar	●
Provision for 2x 205 L Drums	●
Pump, Air Operated for Engine, Transmission, and Hydraulic Oil Dispensing Systems	●
Pump, Air Operated, Bulk Grease Pumping System to suit 55kg Grease Drum	●
Pump, Air Operated, Diaphragm for Diesel Dispensing System	●
Pump, Air Operated, Diaphragm for Waste Oil System	●
Pump, Control Panel, Rear	●
Reservoir, Hand Wash, Includes Soap Dispenser	●
Reservoirs, Fluid, Includes Manual Filling and High Speed (Fast Fill) Fluid Connectors	●
Reservoirs, Fluid, Resiliently Mounted	●
Service Control Panel, Rear	●
Storage Compartments, Closed 2x	●
Storage Compartments, Open 4x	●
Tank, Diesel 5000 L	●
Tank, Engine Oil 300 L	●
Tank, Hydraulic Oil 300 L	●
Tank, Transmission Oil 300 L	●
Tank, Waste Oil 300 L	●

Other

Brakes, Park, Onboard, Release for Machine Retrieval	● ●
Engine, Enclosures, Hinged	●
Film, GP Reflective, Fluorescent Yellow	● ●
Film, GP Reflective, Fluorescent Orange	● ●
Fire Extinguisher, 4.5 kg, Hand Held Dry Chemical Powder 4A:60B:E LH and RH Side	● ●
Fire Extinguisher, 9 kg, Hand Held Dry Chemical Powder 6A:80B:E LH and RH Side	● ●
Fire Suppression System, Ansul A101 Dry Chemical Powder, Engine Shutdown	● ●
Fire Suppression System, Sandvik Aqueous-Film Forming Foam, Engine Shutdown	● ●
Grease Lubrication System, Centralised, Manual	●
Grease Lubrication System, Automatic	●
Lift, Tie Down and Retrieval Points (Front and Rear)	●
Mudguards	●
Radiator, Cap, Manual Pressure Release	●
Scheduled Oil Sampling (SOS) ports	●
Steering, Frame Lock Link	●
Steering, Secondary	●
Tyres, Tubeless Rims (14.00 R20)	●
Tyre and Rim, Spare (14.00 R20)	●
Unit Number Placard	●
Wheel Chocks	● ●

OVER 45 YEARS IN THE MINING INDUSTRY.

Elphinstone Pty Ltd is an established Caterpillar Original Equipment Manufacturer with over 45 years' experience in the mining industry. Elphinstone specialises in the design, manufacture and support of quality equipment for the global underground and surface mining industries.

The Elphinstone range of Underground Mining Support Vehicles combines practical design, the latest technology and quality manufacturing to ensure reliable performance.

The current product range includes specialised underground support vehicles, mine extraction devices, extended distance off-highway haulage trucks and water tanks customised to suit Caterpillar articulated trucks.

As an authorised Caterpillar Original Equipment Manufacturer, all Elphinstone products are sold and supported via the global Cat® dealer network.

E10 FUEL & LUBE

For more complete information on Elphinstone products, dealer services, and industry solutions, visit www.elphinstone.com or contact your local Cat dealer.

Material and specifications are subject to change without notice. Featured machines in photos may include additional equipment.

Elphinstone and their respective logos, as well as corporate and product identity used herein, are trademarks of Elphinstone and may not be used without permission.

© 2024 Elphinstone. All rights reserved.
Made in Australia for export.

ELPHINSTONE



HM06630-03 (01-2024)