



WR820

WATER TANK



Elphinstone Underground Support Solutions
elphinstone.com

ELPHINSTONE

UNDERGROUND RELIABILITY



TECHNICAL SPECIFICATIONS

Engine

Engine Model	Cat C11 ACERT Tier 3	
Gross Power SAE J1995	242 kW	325 hp
Net Power ISO9249	239 kW	321 hp
Net Power SAE J1349	237 kW	317 hp
Displacement	11.15 L	680 in ³
Bore	130 mm	5.1 in
Stroke	140 mm	5.5 in
Number of Cylinders	6	
Max Torque @ Rated Speed	1430 Nm @ 1300rpm	
Derating Altitude 3048 m 9843 ft	3048 mn	9843 ft

- These ratings apply at 1,800 rpm when tested under the specified standard conditions
- Net power advertised is the power available at the flywheel when the engine is equipped with fan, air cleaner, muffler and alternator. No derating required up to 3,000 m (9,843 ft) altitude
- Based on standard air conditions of 25° C (77° F) and 99 kPa (29.32 in Hg) dry barometer. Used 35 API gravity fuel having an LHV of 42,780 kJ/kg (18,390 BTU/lb) when used at 30° C (86° F) [ref. A fuel density of 838.9 g/L (7.001 lb/gal)]

Electrical

Alternator	150 amp
Electrical System	24 V
Battery - Quantity	2
Battery - Volts	12 V
Battery - Capacity	1400CCA
Starting System	Direct Electric

Powertrain

Travel Speed - Fwd. 1st	5.5 km/h	3.4 mph
Travel Speed - Fwd. 2nd	10.4 km/h	6.5 mph
Travel Speed - Fwd. 3rd	15.8 km/h	9.8 mph
Travel Speed - Fwd. 4th	24.2km/h	15.0 mph
Travel Speed - Rev. 1st	6.1 km/h	3.8 mph
Transmission	4 fwd / 1 rev powershift	
Transmission Cooler Type	Tube and Bund	
Steering, Frame Articulation	+/- 42.5°	
Brakes - Service Type	Multiple WET disc enclosed Spring applied wheel ends	
Brakes - Parking Type	Multiple WET disc enclosed Spring applied wheel ends	
Tyres	18.00 R25	

Hydraulic System

Circuit Type	Closed centre variable flow	
Pump Type	Axial piston	
Pump Output	174 L/min	46 gal/min
Relief Valve Setting	21,000 kPa	3,045 psi
Steering Valve	Direct link, non follow	
Steering Cylinder - Bore	114.3 mm	4.5 in
Steering Cylinder - Stroke	437.5 mm	17.22 in
Steering Cylinder - Rod Diameter	50.8 mm	2 in

Service Refill

Fuel Tank	361 L	94 gal
Cooling System	67 L	18 gal
Differential, Final Drive - F	55 L	14.5 gal
Differential, Final Drive - R	55 L	14.5 gal
Engine Oil	41 L	11 gal
Transmission, Torque Converter	36 L	9.5 gal
Hydraulic Tank	151 L	49 gal
Brake Cooling Tank	67 L	18 gal

Weights

Gross Vehicle Weight (GVM)	42,631 kg	93,985 lbs
Tare Weight	26,411 kg	58,226 lbs

*Tare weight includes one operator and a full tank of fuel.

Speed on Grade

Grade	Vehicle Speed (km/h)				
	1st Fwd	2nd Fwd	3rd Fwd	4th Fwd	1st Rev
1:7 (14%) Empty (26,411 kg)	5.5	10.4	15.8	-	6.1
1:7 (14%) GVM (42,631 kg)	5.5	10.4	-	-	6.1

*Note: 2% rolling resistance

Water Tank

Camera	2x Reverse / Auxiliary on Rear of Tank, 1x on Top / Front of Tank Facing Rearward	
Drain Valve	76 mm	3 in
Gauge, Pump Pressure	Rear Side of Tank	
Gauge, Water Level	Rear Side of Tank	
Lights, Work	4x on Rear of Tank	
Port, Top Fill	High Volume Port for Top Filling of Tank	
Port, Side Fill	Filling Tank from Side of Machine	
Spray Head, Rear, 1 x 76 mm (3 in)	Rear / Centre for Dust Suppression	
Spray Head, Side, 2 x 38 mm (1.5 in)	LHS / RHS for Dust Suppression	
Tank, Auto Low Level Shut Off Switch		
Tank, Water	16,145 L	4265 gal

Standards

ROPS/FOPS	ISO 3471:2008 / ISO 3449:2005
Steering	ISO 5010:2007
Braking	ISO 3450-2011/CSA-M424.3-M90



MACHINE DIMENSIONS

Turning Radius

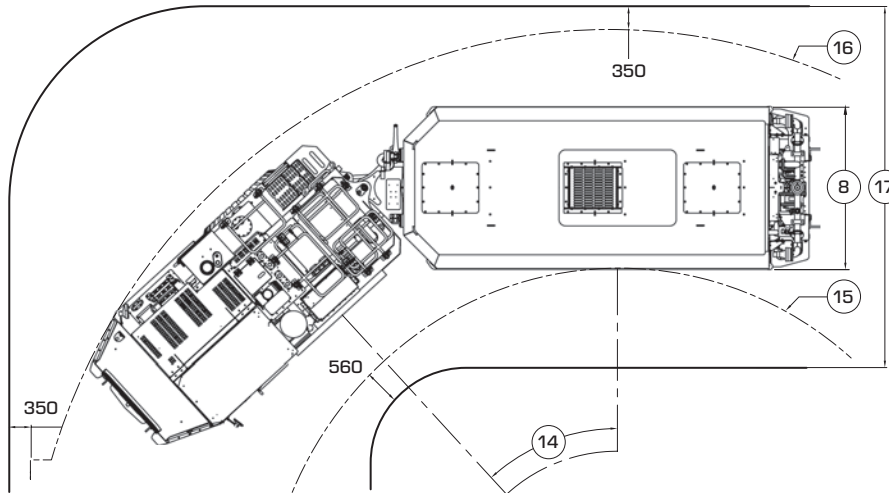

Side View and Drive Size

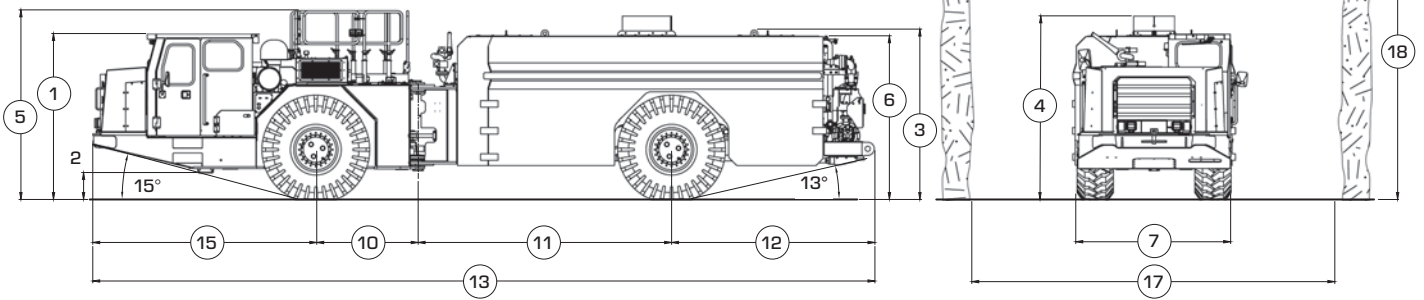

Dimensions

1	Height - Top of Cab	2515 mm	8 ft 3 in
2	Height - Ground Clearance	410 mm	1 ft 4.1 in
3	Height - Top of Lift Points	2575 mm	8 ft 5.4 in
4	Height - Top of Fill Port	2630 mm	8 ft 7.5 in
5	Height - Top of Rails	2870 mm	9 ft 4.9 in
6	Height - Top of Tank	2490 mm	8 ft 2 in
7	Width - Machine Front Frame	2445 mm	8 ft 0.3 in
8	Width - Machine Rear Frame	2445 mm	8 ft 0.3 in
9	Length - Front Axle to Bumper	3390 mm	11 ft 1.5 in
10	Length - Front Axle to Hitch	1560 mm	5 ft 1.4 in
11	Length - Hitch to Rear Axle	3857 mm	12 ft 7.8 in
12	Length - Rear Axle to Rear Guard	3059 mm	10 ft 0.4 in
13	Length - Overall	11860 mm	38 ft 10.9 in
14	Articulation	42.5°	

Drive Size

15	Radius - Inside Clearance	5280 mm	17 ft 3.9 in
16	Radius - Outside Clearance	8925 mm	29 ft 3.4 in
17	Width - Drive Clearance	5500 mm	18 ft 0.5 in
18	Typical Minimum Height Portal	5000 mm	16 ft 4.8 in



STANDARD AND OPTIONAL EQUIPMENT

● Standard ● Optional ● Safety

Powertrain	
4WD Transfer Box	●
Air Cleaner, 2-Stage with Rain Cap	●
Axle Breathers, Remote Mounted	●
Brakes - Engine Compression	●
Brakes - Parking, Four Wheel Spring Applied, Pressure Release, Enclosed Disc	●
Brakes - Service, Four Wheel Spring Applied Pressure Release, Enclosed Disc	●
Coolant, Arctic Extended Life -52°C Protection	●
Coolant, Extended Life -37°C Protection	●
Cooling Package, Radiator And Aftercooler	●
Driveline Slip-Joint, Lubricated for Life	●
Engine, Exhaust Manifold, Shielded and Insulated	●
Engine, Cat C11, ACERT Technology, ATAAC	●
Engine, Exhaust, Diesel Particulate Filter With Back Pressure Monitoring	●
Engine, Overspeed Inhibitor	●
Engine, Shutdown System to Idle/Stop	●
Fan, Hydraulic, Sucker, Temperature Controlled	●
Filters, Fuel (Primary/Secondary)/Engine Air, Hydraulic Oil, Pump Case Drain, Brake Cooling Oil, Implement	●
Final Drives, Inboard Planetary	●
Fire Resistant Sheathing on Fuel Lines, External	●
Front Axle, Oscillating	●
Fuel Tank, High Capacity	●
Fuel Transfer Pump (Mechanical)	●
Lock-Up Torque Converter	●
Low Transmission Oil Pressure Monitoring	●
Manual Fuel Shutoff Valve at the Tank	●
Muffler/Catalytic Converter	●
Stainless Steel Braided Fuel Lines, External	●
Steering, Rotary Metering Pump	●
Transmission, Power-Shift (4F/1R) With Auto-Shift Function	●
Universal Joints with Lube Points	●
Fast-fill systems	
Coolant, Engine Oil, Hydraulic Oil, Transmission Oil, Brake Cooling Oil	●
Fuel	●
Fuel with Machine Isolation	●
Operator Environment	
Brake Retarder Control, Automatic	●
Brake Retarder Control, Manual	●
Brakes, Park, Onboard - Push to Engage	●
Brakes, Park, Onboard - Pull to Engage	●
Cabin, Open, ROPS/FOPS	●
Cabin, Enclosed, ROPS/FOPS, Climate Controlled Air Conditioning System, Window Sliding Operator, Windshield Wiper Washer, Window Emergency Egress Seals	●
Camera, Off-side	●
Camera/Monitor, Reversing	●
Door Pocket	●
Fire Extinguisher, 4.5 kg, Hand Held Dry Chemical Powder 4A:60B:E LH Side	●
Heated Mirrors, Rear View	●
Holder, Water Bottle	●
Light, Dome	●
Light, Entry	●
Mirrors, Rear View	●

Operator Environment	
Rear Window Guard	●
Seat Cover	●
Seat, Suspension - Active Air	●
Seat, Suspension - Air	●
Seat, Suspension - Mechanical	●
Seatbelt, 2-point, Retractable Lap	●
Seatbelt, 2-point, Retractable Lap, Occupancy Indicator	●
Steering Wheel, Tilt and Telescoping	●
Storage Compartment	●
Instrumentation, Gauges	
Brake, Accumulator Pressure	●
Brake, Parking, Pressure	●
Brake, Service, Pressure	●
Engine, Coolant Temperature	●
Engine, Oil Pressure	●
Fuel Level	●
Speedometer	●
Steering System Pressure	●
Tachometer	●
Transmission, Oil Temperature	●
Instrumentation, Warning Indicators	
Brake, Accumulator Oil Pressure	●
Brake, Cooling Filter Back Pressure	●
Brake, Cooling Oil Level	●
Brake, Cooling Oil Temperature	●
Brake, Fault	●
Brake, Parking, Application	●
Charging System	●
Door Open	●
Emergency Stop, Activation	●
Engine, Coolant Level	●
Engine, Coolant Temperature	●
Engine, Fault	●
Engine, Oil Pressure	●
Hydraulic, Oil Level	●
Hydraulic, Oil Temperature	●
Lights, Work - Bowl	●
Lockup Clutch	●
Primary Steering Pressure	●
Retarder On	●
Seat Belt	●
Secondary Steering Pressure	●
Stabilizers Down	●
Torque Converter, Oil Temperature	●
Transmission Fault	●
Transmission Filter Bypass	●
Instrumentation, Digital Data	
Computerised Diagnostics and Monitoring	●
Gear and Direction	●
Odometer	●
Service Hour Meter	●
Electrical	
Accessory Power Port (12 V)	●
Alarm, Back-up	●
Alternator, 100 amp	●
Alternator, High Output, 150 amp (Part of Enclosed operator station (FOPS/ ROPS))	●



STANDARD AND OPTIONAL EQUIPMENT

● Standard ● Optional ● Safety

Electrical

Auxiliary Start Receptacle	●
Batteries, Maintenance Free (2x 1400 CCA)	●
Battery Isolation, Lockable Disconnect Switch (2 Pole)	●●
Battery Isolation, (4 Pole)	●●
Beacon, Flashing, LED, Front/Rear of Cab (Amber)	●●
Beacon, Flashing, LED, Front/Rear of Cab (Blue)	●●
Beacon, Rotating, Cab, Mounted (Various Colours Available)	●●
Diagnostic Connector	●
Digital Inclinometer Display, Dashboard	●●
Electrical Connectors, Sealed	●
Electronic Monitoring System	●
Emergency Stop - Cabin	●●
Emergency Stop - Ground Level, RH Side, Engine Bay	●●
Emergency Stop - Ground Level, LH Side Front	●●
Horn, Warning	●●
Lights, Stop/Tail/Turn	●
Lights, Brake and Tail	●
Lights, Headlights with Dip Switch	●
Lights, Work, Rear - Cab Mounted	●
Lights, Work, Rear of Tank	●
Lights, Work, Water Cannon	●
Lights, Reversing	●
Operator Presence	●●
Starter Isolator, Lockable	●●
Starter Isolator, (4 Pole)	●●
Starter, Electric, Heavy Duty	●
Starting and Charging System (24 V)	●
USB Charger Outlet (5 V)	●

Hydraulics

Bowl Motor with Quick-Connect Lines	●
Brakes, Cooling Filters	●
Brakes, Cooling Oil Coolers	●
Brakes, Separate Cooling Tank	●
Burst Protection, Hoses	●●
Closed Centre, Load Sensing System	●
Hydraulic Oil Cooler	●
Line Filter, Full Flow Return	●

Water Tank & Work Tools

Pump-Water Pressure Gauge	●
Spray Head - Rear, Centre, 76 mm (3 in)	●
Spray Head - Rear, Both Sides, 38 mm (1.5 in)	●
Tank, Automatic Low Level Shut Off Switch	●
Tank Level Gauge	●
Water Cannon with Tilt and Slew, Variable Water Output	●
Water Pump, Centrifugal - High Volume	●
Water Pump, Hydraulic Motor Pressure Gauge	●
Operator Display	
Dust Suppression Water Output Rate (Variable)	●
Pump, Control Metrics	●
Tank, Low Level Alarm	●
Tank, Level Indicator	●
Visual Indicator, Active Spray Head	●

Other

Anti-Corrosion Protection Spray	●
Articulation Lock Link	●●
Centralised Service Centre (Grouped Filters, Transmission Fill and Engine Fill)	●
Ecology Drains (Hydraulic Tank)	●
Engine, Enclosures, Hinged	●
Film, Gp Reflective, Flourescent Orange	●●
Film, Gp Reflective, Flourescent Yellow	●●
Fire Extinguisher, 9 kg, Hand Held Dry Chemical Powder 6A:80B:e LH and RH Side	●●
Fire Suppression System, Ansul A101 Dry Chemical Powder, Engine Shutdown	●●
Fire Suppression System, Sandvik Aqueous-Film Forming Foam, Engine Shutdown	●●
Firewall	●●
Grease Lubrication System, Automatic	●
Grease Lubrication System, Centralised, Manual	●
Guards, Pivoting, Under Engine And Transmission	●
Handrails, Fixed for Top Covers	●
Handrails, Folding for Top Covers	●
Handrails, Painted Contrasting High-visibility Green	●●
Ladder, Folding, Engine Access	●●
Lift, Tie Down and Retrieval Points (Front and Rear)	●
Mudguards	●
Oil Sampling Ports, SOS SM	●
Radiator Ap, Manual, Anti-scald Pressure Release	●●
Rim Identification	●
Rim, Spare (18.00R25)	●
Steering Lockout, Park Brake Engaged	●●
Steering, Secondary	●●
Tank, Coolant Make Up	●
Tooling - Engine Timing	●
Tyre and Rim, Spare (18.00R25)	●
Tyres and Tubeless Rims (18.00R25)	●
Wheel Chocks 2x (Checkers, MC3010)	●●
Wheel Chocks 2x (Checkers, UC1210)	●●
Wheel Nut Retention Indicators	●●

OVER 45 YEARS IN THE MINING INDUSTRY.

Elphinstone Pty Ltd is an established Caterpillar Original Equipment Manufacturer with over 45 years' experience in the mining industry. Elphinstone specialises in the design, manufacture and support of quality equipment for the global underground and surface mining industries.

The Elphinstone range of Underground Mining Support Vehicles combines practical design, the latest technology and quality manufacturing to ensure reliable performance.

The current product range includes specialised underground support vehicles, mine extraction devices, extended distance off-highway haulage trucks and water tanks customised to suit Caterpillar articulated trucks.

As an authorised Caterpillar Original Equipment Manufacturer, all Elphinstone products are sold and supported via the global Cat® dealer network.

WR820 WATER TANK

For more complete information on Elphinstone products, dealer services, and industry solutions, visit www.elphinstone.com or contact your local Cat dealer.

Material and specifications are subject to change without notice. Featured machines in photos may include additional equipment.

Elphinstone and their respective logos, as well as corporate and product identity used herein, are trademarks of Elphinstone and may not be used without permission.

© 2024 Elphinstone. All rights reserved.
Made in Australia for export.

ELPHINSTONE



HM06626-03 (01-2024)